

# **WiselImage Geo Quick Start**

© 2005 Consistent Software

<b>WisImage Installation</b> .....	<b>4</b>
System Requirements .....	4
Software or Hardware Protection .....	4
Installation .....	4
Licensing .....	5
<b>WisImage Document</b> .....	<b>6</b>
WisImage Document .....	6
WisImage Document Properties .....	6
Document Coordinate System .....	7
Inspector .....	8
Image Manager .....	8
Layer Manager .....	8
Block Manager .....	9
Line Style Manager .....	9
Text Style Manager .....	9
<b>Getting Started</b> .....	<b>10</b>
Opening Files .....	10
Saving Files .....	10
Import and Export .....	11
Navigating in a Document .....	12
Precise Drawing Tools .....	13
Image Clip .....	15
WisImage Clipbooks .....	16
Print .....	16
<b>WisImage Objects</b> .....	<b>17</b>
Raster Images .....	17
Vector Objects .....	18
Raster Drawing Mode .....	23
<b>Selection</b> .....	<b>23</b>
Type of Data Selected .....	24
Selection Modes .....	25
Raster Selection Methods .....	25
Tuning Raster Selection .....	27
Filter for Data Selection .....	27
<b>WiseObject Selection</b> .....	<b>28</b>
<b>Editing WisImage Objects</b> .....	<b>28</b>
Editing Data, Selected with Object Selection .....	28
Editing Vector Objects .....	31
Editing Raster Images .....	31
Editing Vector Polyline .....	33
Search and Replace .....	34
<b>Enhancing Scanned Images</b> .....	<b>34</b>
Deskewing .....	34

Filtering Monochrome Images .....	35
Separating Monochrome Images by Size .....	38
Eliminating Distortions Using Calibration .....	38
Four-Point Correction.....	40
Autocorrecting Image .....	41
Editing Raster Text .....	41
Restoring Images of Poor Quality .....	42
<b>Editing Color Images .....</b>	<b>44</b>
Correcting Image Brightness, Contrast, Hue, and Saturation.	44
Correction by Histogram.....	44
Color Filters .....	45
Convert to RGB, Greyscale, 8-bit indexed.....	47
Separating Color & Greyscale Images to Monochrome Layers	48
Advanced Color Tools.....	49
<b>Rasterizing; Merging Raster Images.....</b>	<b>52</b>
Rasterizing Vector Data.....	52
Merging Raster Images .....	52
<b>Tracing .....</b>	<b>53</b>
Tuning Tracing .....	53
Tracing Modes and Commands .....	55
How to Trace .....	55
Tracing Lines, Arcs, Circles, Outlines.....	56
Tracing Hatches .....	56
Tracing Polylines .....	57
Tracing Outlines .....	58
Tracing Raster Symbols.....	59
<b>Automatic Vectorization, Text Recognition.....</b>	<b>62</b>
Tuning Vectorization .....	62
How to Vectorize .....	64
Text Recognition .....	64
Training OCR .....	67
Automatic Raster to Contours vectorization .....	67
Automatic Color vectorization .....	68
Correcting Vectorization Results .....	70
<b>Working with Raster Symbols .....</b>	<b>74</b>
Training to Recognize Symbols.....	74
Tuning Symbol Recognition Options.....	75
Selecting, Tracing, and Vectorizing Raster Symbols .....	76
<b>Batch and Script .....</b>	<b>76</b>
Script Studio.....	76
Batch Studio.....	78
<b>Customizing WiseImage .....</b>	<b>79</b>
Customizing Program Parameters .....	80
Customizing Interface .....	80

## WiselImage Installation

### System Requirements

To work with the program you need the following:

- Pentium processor
- 128 MB RAM
- Microsoft Windows NT 4 /98 / 2000 / ME / XP
- Hard disk with 70 MB of free space.

### Software or Hardware Protection

WiselImage uses the software or hardware protection system. It offers the flexibility to use the program in a single user or in a network environment. To use WiselImage you need to set up the license for the program. The procedure of obtaining and setting up the license is described in the Installation chapter.

### Installation

1. Insert CD-ROM with the WiselImage in the CD-ROM drive. If the auto start function of your computer is on, the dialog box of the program product list will be displayed.
2. To open the installation dialog manually, start the SETUP.EXE file from the CD ROM root folder.
3. Select an appropriate product from the list.
4. You will see the WiselImage image first, then the *Customer Information* dialog box.
5. Enter your name into the *User Name* box, then enter your organization name into the *Company Name* box, and enter the serial number of your product copy from software CD-ROM or Box into the *Serial Number* box. Check the correctness of the information entered, as after the installation is completed, there is no possibility to change these data. Click on the *Next* button to continue. The *Choose Destination Location* box will appear.
6. It specifies the folder name and the disk, where the WiselImage program will be installed. You can accept the default path or specify a location for the installation to be made with the *Browse* button. Click on the *Next* button to continue.
7. You can change a type of installation in the displayed box. If you do not want to make changes, click on the *Next* button. The Program and the example files will be installed. If you do not want to install examples files, select the *Compact* type and click on *Next*.
8. The product can have other types of installation depending on its version. Their description is provided in the lower box of the dialog box.
9. After selecting a type of installation, the *Select Program Folder* box will appear prompting to change the folder name of the

system menu where there will be a shortcut of WiselImage start. The *Program Folders* already has a name, which you can accept by clicking on the *Next* button. If you want to change this name, enter another one and then click on the *Next* button.

10. The *Setup Status* box will appear and the copying of the WiselImage files on the computer will begin. After the copying is completed, you can start the program from the folder to the system menu with the name you specified in the previous dialogue.
11. The installation program creates on the hard disk a folder for the WiselImage program where all necessary files are copied and it places a shortcut for WiselImage in the Windows system menu.

## Licensing

After the installation is completed, you need to obtain the license to use WiselImage.

There are two different cases: Single-user environment and Installation on network.

### Single-user environment

To setup the license for the first time you have to use the *Registration Wizard*.

- Click Start on the taskbar, then choose Programs.
- Click WiselImage, then choose the Registration Wizard menu item.
- Follow the instructions. If you have already got the license – attach it, in another case - ask for the license by e-mail.

### Installation on network

The network installation procedure is described in the LANSETUP.PDF file on Consistent Software CD.

### Using Hardware Lock (optional)

- If you are using Windows NT or Windows 2000, you must have SENTINEL driver installed. This can be found on the WiselImage installation disk.
- Insert hardware lock in the printer or USB port of your computer and start installation. After completing the installation start Registration Wizard and choose *I want to get the license*. Click *Next*. Follow instructions on the screen.
- When Registration Wizard finishes, copy registration information highlighted in dialog window and sent it to [getlicense@csoft.com](mailto:getlicense@csoft.com) or just click *Send e-mail* button.
- Depending on the installation type you will get additional information on using your license.

## WiselImage Document

**Brief description:** This section is devoted to WiselImage documents and document properties. You will learn how to customize the document and set a user coordinate system. This lesson also demonstrates the main dialogs – Inspector, Image manager, Layer manager, and Block manager.

### WiselImage Document

A WiselImage document can contain both raster images and vector objects at the same time; its workspace is unlimited. You can load an unlimited number of color, greyscale and monochrome raster images (of course, capability and work speed depend on your computer resources). The document also stores tool settings, which are used in the working process.

If the document contains several raster images, you can work simultaneously with them.

WiselImage supports multi-document interface (MDI), i.e. the program can have several documents loaded, and you can simultaneously run different operations in all of them.

WiselImage document files have a CWS extension.

#### *How are raster images stored in the document?*

There are two different ways to store raster images in WiselImage:

1. **Linked** raster images – are stored separately from the document file
2. **Embedded** raster images– are stored in the WiselImage document file

### WiselImage Document Properties

If you start working with a new WiselImage document, you can set its properties. The tuned document can be saved as template for further use.

---

*See section Customizing Program Parameters on page 80 for information on template selection*

You can set up font type and height, color, current layer; line type and width, etc. as properties of a document.

The properties of WiselImage objects may be set **By layer**. (in this case the properties of created objects inherit the properties of the layer they belong to); or **By block** (in this case, the objects comprised in the block inherit this block's properties).

---

*See section Layer Manager on page 8 for information on setting layer properties.*

#### *How to set up document properties*

- Open the **Inspector** (choose **Inspector** from the **Tools** menu)
- Make sure, that no object is selected – otherwise the **Inspector**

displays its properties. To unselect all you can press the **UnSelect All** button, located on the **Select** toolbar (utmost right).

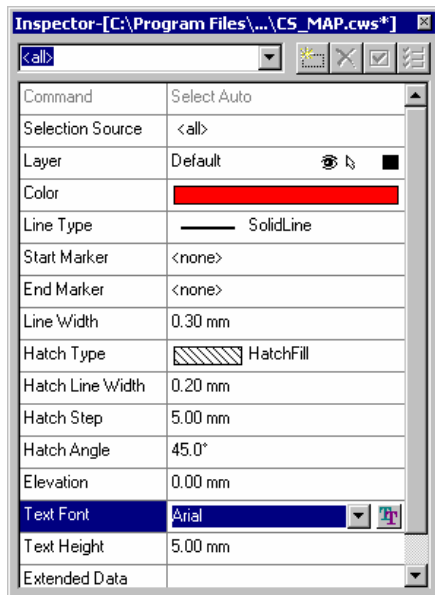

- Make sure that no command is being executed – otherwise the **Inspector** displays its parameters. Press **Esc** to cancel all commands.
- Select desirable values from the combo-box or enter them in the corresponding fields of the **Inspector**.

You can save the tuned document as a template for further use.

## Document Coordinate System

You can work in World Coordinate System or set up multiple User Coordinate Systems (UCS).

### How to set up a UCS

- Choose **Coordinate System** from the **Tools** menu.

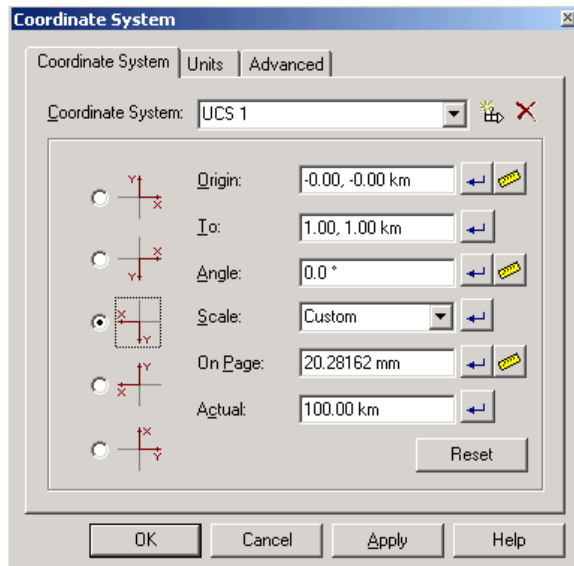

- In the **Units** tab, specify linear and angle measurement units and their accuracy

You can specify units for measuring line width separately in the **User** field of the **Units** tab.

- In the **Coordinate System**

tab, click on  button to create New Coordinate System

- Choose UCS axis direction using one of the four corresponding radio buttons.
- Define UCS parameters – origin, skew angle relative to X-axis, and scale.

You can specify the origin relative to another point which coordinates are known to you, for example – points with known coordinates on a map. To do so, use the rulers of **Origin** to specify a point with known coordinates on the screen, and then enter its real coordinates in **To**:

In case you also need to specify a new scale, first specify the desired

scale, press **Apply**, and then specify the relative origin position as described above.

## Inspector

Using the Inspector you can view and edit the following information:

- WiselImage document settings

---

*See page 6 for detailed information on setting document properties.*

- Properties of selected object(s)
- Run command parameters

### *How to open the Inspector*

Choose *Inspector* from the *Tools* menu



Or press the *Inspector* button, located on the *Properties* toolbar

## Image Manager

Using the Image Manager you can:

- view all images loaded in the document
- get information on image properties and edit some of them
- save, delete and create new raster images
- turn on/off visibility and lock (unlock) raster images
- change the way of storing raster images in the document (in a separate file – linked, or in the document file - embedded)
- change the page order in a multipage TIFF-file.



To embed a raster image saved in a separate file to the document, select this image from the Image Manager list, and then press the *Embedded* button



To save the embedded raster image in a separate file, select this image from the Image Manager list, and then press either *Save* or *Save as* button



To change the page order in the multipage TIFF-file, select the image and move it up or down using *Move Up* or *Move Down* button

### *How to open Image Manager*

Choose *Images* from the *Tools* menu



Or press the *Image Manager* button located on the *Properties* toolbar

By pressing the *Details* button of the *Images* dialog you will get all information on the selected image properties, some of which can be edited.

## Layer Manager

A WiselImage document consists of layers on which all objects are

placed. Layers have properties (color, line type and line width, font, etc.). Objects can have their own properties or inherit properties from the layer on which they are placed.

Using the Layer Manager you can:

- view and edit information on layer properties
- set the current layer – on which new objects will be placed
- Create new layers and delete existing ones.  
You can only delete a layer if it does not contain any object and it is not current.
- Turn on/off layer visibility; allows or prevents the selection or modification of objects that belong to a certain layer.

#### ***How to open Layer Manager***

Choose *Layer* from the *Tools* menu.



Or press the *Layer Manager* button located on the *Properties* toolbar.

By pressing *Details* of the *Layers* dialog box you get full information on the selected layer properties, some of which can be edited.

### **Block Manager**

Using the Block Manager, you can:

- get information on all blocks and their insertions in a document
- view blocks in the Preview window
- edit block properties (if a block has only one insertion)
- save blocks as separate files.

#### ***How to open Block Manager***

Choose *Blocks* from the *Tools* menu



Or press the *Blocks Manager* button located on the *Properties* toolbar

### **Line Style Manager**

Using the Line Style Manager, you can get information on all lines styles in a document and create new style patterns.

#### ***How to open Line Style Manager***

Choose *Style* from the *Tools* menu

### **Text Style Manager**

Using text styles, you can change text properties for a number of objects on the fly. Just modify any parameter of the required text style, and every WiselImage text in this document which inherits the value for this property from the modified text style will be changed immediately

#### ***How to open Style Manager***

Choose *Text Style* from the *Tools* menu

## Getting Started

**Brief description:** This section provides you with a basic knowledge of WiselImage – opening, saving, file export and import, navigating in document, drawing with precision, clipping raster images and printing. You will also learn how to create and work with WiselImage clipbooks.

### Opening Files

Using the *Open* command of the *File* menu you can load:

- **WiselImage documents (\*.cws)**
- **AutoCAD files (\*.dwg, \*.dxf)** (including hybrids, which contain raster images, – only for versions AutoCAD R14 and higher).
- **Raster images:** formats: TIF (include Multipage Tagged Image File); RLC; BMP; IPG; IPEG; PCX; C4; CAL; TG4; MrSID  
if you open raster images using the *Open* command of the *File* menu, each of them is loaded in a new document. If you want to open raster images in the current document, use the *Image* command of the *Insert* menu.
- **Multipage TIF-files.** All file pages are loaded in the document.  
If you need to load several pages from a multiple TIF-file, use the *Image* command of the *Insert* menu. You can view and load only the desired pages using the *Load Page* dialog box.
- **Hybrid and vector files,** created in previous versions of the program (\*.ws, \*.aws, \*.vc6, \*.vc5).

You can open files using special tool – *Explore*. It meets and exceeds the requirements for file operations within WiselImage for every exacting user. It gives all possibilities to operate with files presented in Windows Explorer and even more. Some required features like Filter by Extension, Bookmarks, Favorites and much more, decreases the time of file operations dramatically. To launch it – select appropriate command from the *Tools* menu.

### Saving Files

#### *Saving WiselImage documents*

- Specify in the Image Manager the way you want to store raster images contained in the document – either in separate files or embedded in the document file.

---

*See section Image Manager on page 8 for detailed information on the ways to store raster images in the document file.*

- Choose *Save As* from the *File* menu. Specify the document name, choose extension \*.cws from the *Save as type* list.

#### *Saving document in AutoCAD format*

- Choose *Save As* from the *File* menu. Specify the document name, choose extension \*.dwg (\*.dxf) from the *Save as type* list.
- Press the *Options* button and specify AutoCAD version for the

saved document.

If you save data:

in format of AutoCAD R14 (AutoCAD LT 97) versions and higher	Program saves the hybrid document, which contains vector objects and raster images. If the document contains embedded raster images, the program suggests saving them in separate files (as AutoCAD hybrid document is always linked).
in format of AutoCAD R13 (AutoCAD LT 95) versions and lower	Program saves vector data only.

### ***Saving raster image***

If you want to save only the raster image:

- Open *Image Manager* by choosing *Images* from the *Tools* menu.
- Select a raster image to save and press the *Save* or *Save As* button. Specify the image name, format, and additional options for the specified format.

### ***Saving multipage raster TIF-file***

- Select images to save in multipage raster TIF-file.

---

*See page 26 for detailed information on raster image selection.*

- Choose *Save As* from the *File* menu. Choose *Multipage Tagged Image File* from the *Save as type* list
- Specify the name and additional options for TIF format.

## **Import and Export**

To import a file, choose *Import* from the *File* menu. Specify the vector file and press *Open*.

*Table of import formats and imported objects.*

Import format	Imported object
<ul style="list-style-type: none"> <li>• <i>Microstation</i> format (*.dgn).</li> </ul>	Vector objects

To export in the specified formats:

- Select data, if you want to export only selected objects.

---

*See page 25 for detailed information on raster and vector selection.*

- Choose *Export* from the *File* menu. Specify the name and additional options for the specified format.
- If you want to export only selected objects select the *Selection Only* checkbox.
- Press *Save*.

*Table of export formats and exported objects.*

Export format	Exported object
---------------	-----------------

<ul style="list-style-type: none"> <li>• <i>WiselImage</i> format (*.cws)</li> <li>• <i>AutoCAD</i> format (*.dwg, *.dxf) of R14 (AutoCAD LT 97) versions and higher</li> </ul>	Vector objects and/or raster images
<ul style="list-style-type: none"> <li>• <i>AutoCAD</i> format (*.dwg, *.dxf) of R13 (AutoCAD LT 95) versions and lower.</li> <li>• <i>MapInfo</i> format (*.mid).</li> <li>• ESRI shape format (*.shp).</li> </ul>	Vector objects

## Navigating in a Document

Navigation tools are designed to help you work within a document. You can choose navigation tools from the *View* menu or from the *Main* toolbar.

### Standard navigation tools



Zoom All – displays a whole document.



Zoom Previous – returns to the previous display.



Zoom Selected – displays selected objects.



Zoom Window – increases a fragment selected with window, to full screen size.



Zoom In – doubles an image size.



Zoom Out – decreases an image size by half.



Zoom 1:1 – displays the document in real scale.



Pan – moves a document within program window in specified direction.



Zoom Dynamic – turns on the mode in which you can increase scale by moving the mouse up and decrease scale by moving the mouse down.

### Birds Eye



When working with a large document you can use the overall window to display an entire document and the border(s) of current views.

To open the Birds Eye window, choose *Birds Eye* from the *View* menu.

### Turning on/off visibility of vector object width

You can toggle the visibility of vector object widths. If turned off, all vector objects are displayed with zero width (i.e. 1 pixel of display resolution).

To turn on/off visibility of vector object widths choose *Show Width* of the *View* menu turned on/off.

### Turning on/off visibility of raster and vector graphics

For convenient work you can turn toggle the visibility of all vector objects or raster images in the document. The buttons are located in the *View* menu and on the *Main* toolbar.



To turn off (on) the vector visibility press (release) the Hide Vectors button



To turn off (on) the raster visibility press (release) the Hide Raster button

### ***Changing object display order***

You can change the object display order (vector objects and raster images), moving selected objects to front and back, or backward and forward.

Select objects and use the corresponding command from the ***Display Order*** list of the ***View*** menu.

---

*See page 25 for detailed information on raster and vector selection.*

### ***Named views***

You can specify views of different fragments of your document and save them with specified names. The program remembers the current document scale and position on the screen.

To create a new named view:

- Locate a desired image fragment on the screen using the navigation tools described above.
- Enter the view name in the field, located in the right part of the ***Properties*** toolbar.



- Press the  button, located next to the ***Named new*** field.

To delete a named view, select it from the list and press the  button.

### **Precise Drawing Tools**

The following drawing tools are available to aid precise drawing: snap to characteristic points of vector and raster objects, polar snap, grid display, snap to grip nodes; orthogonal drawing mode.



To turn on/off a tool you can use the buttons located in the lower-right part of the screen.

### ***Object snap***

WisImage allows you to snap to characteristic points of vector and raster objects. Furthermore, you can snap to vector and raster objects at the same time. You can also use running snap and snap on

demand.

You can choose snap on demand by right-clicking with the Ctrl key pressed.

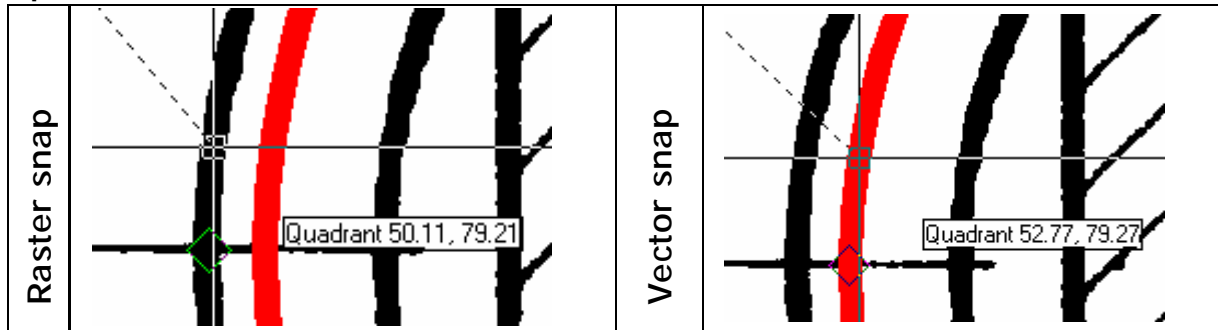

### *Tuning object snap*

Choose *Snap Setup* from the *Tools* menu

In the *Snap Setup* dialog box:

- Choose snap option – raster and/or vector
- Choose snap type(s)
- Set snap on demand – type of objects to snap to.

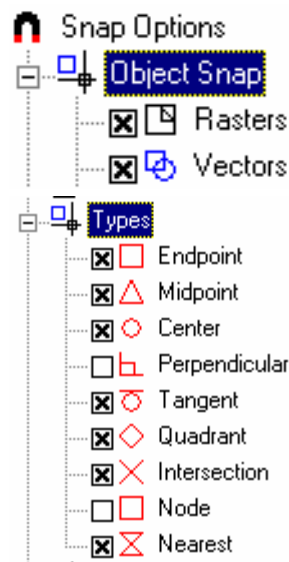

If you have not selected any checkbox in *Snap On Demand*, the program will execute snap to the data selected in the *Object Snap* option.



### *Tuning raster snap*

Raster snap quality is influenced by your image geometry.

You can tune raster snap using the *R2V Conversion Options* dialog box or *Raster Properties* toolbar.

Choose *Conversion Options* from the *Convert* menu, and then go to the *Options* tab.

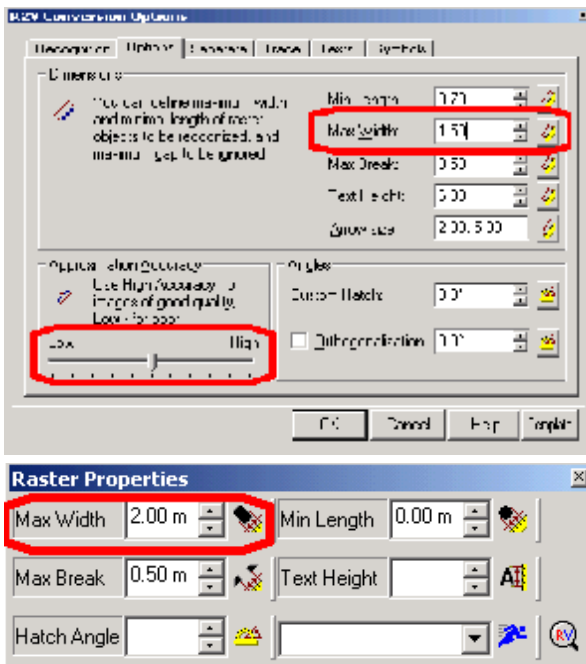

Specify the following values:

**Max Width** – maximum width of a raster object, to which characteristic points you want to snap. Specify this parameter value slightly greater than the maximum width of the raster line.

**Accuracy** – parameter corresponding to your raster image accuracy. Use greater values for images of good quality and smaller values for images of poor quality.

### **Polar snap**

Choose **Snap Setup** from the **Tools** menu. Select the checkbox in the **Polar Snap** field of the **Snap Setup** dialog box, and then specify angle for polar snap.



### **Grid snap**

Choose **Grid Setup** from the **Tools** menu.

In the open **Grid Setup** dialog, specify the grid size in horizontal and vertical directions. Select (clear) the checkboxes for display of grid and grid nodes.

### **Orthogonal drawing mode**

You can switch to orthogonal drawing mode by pressing the ORTHO button, located in the lower-right part of the screen.

The direction for ORTHO mode is defined in correspondence with the document coordinate system axis direction.

## **Image Clip**

You can set a clip area for a raster image. Setting a clip area saves computer resources, speeding up command execution, preventing modification of the image part located outside of the clip.

There are two types of clip – rectangular and polygonal. You can set only one clip on the same image.

### **How to set or reset clip?**

- If there are several images in your document select one to clip.

---

*See page 26 for information on raster image selection*

- Choose **Image Clip** from the **Image** menu, and then **Rectangular** (for rectangular clip) or **Polygonal** (for arbitrary shaped clip).

- To reset clip choose *Image Clip* from the menu *Image*, and then *Reset*.

## WiselImage Clipbooks

You can store raster, vector and hybrid objects in WiselImage clipbooks. You can copy any unit comprised in the clipbook and place them anywhere in your document.

Clipbooks are stored in separate files; their component units can be used in different documents. You can open several clipbooks at the same time.

- To open a new clipbook choose *Clipbook* from the *Tools* menu
- To open an existing clipbook choose *Clipbook* from the *Tools*



menu, and then press the *Open* button  , located in the clipbook window. Find the file of the desired clipbook, and then press the *Open* button.

- To add a new unit to the clipbook:
  - Choose raster, vector or hybrid unit

---

*See section Selection on page 23 for information on raster, vector and hybrid selection methods.*

- Drag the selected objects to the clipbook or copy the selected object using the *Copy* command of the *Edit* menu or with the Ctrl+C acceleration keys. Then place cursor on the clipbook field and right-click; choose *Paste* from the appeared context menu.

- To save the new or modified clipbook press the   *Save* or *Save as* button.

## Print

To open the *Print* dialog, choose *Print* from the *File* menu.

If raster images and vector objects are located one over another, before printing you should set up raster images visibility in *Image Manager* and the object display order using the *Display order* command of the *View* menu.

---

*See section Changing object display order on page 13 for information on object display order.*

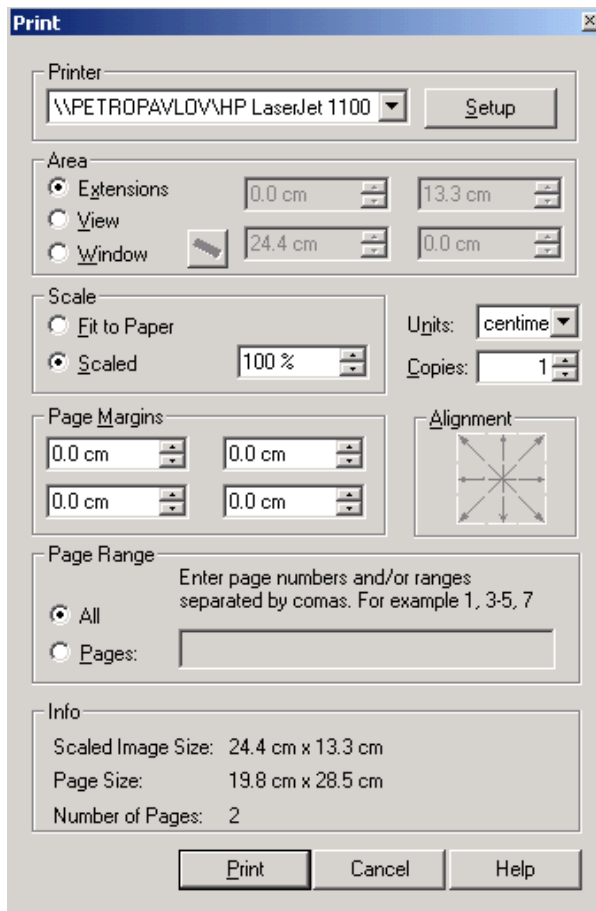

- Using the *Printer* field you can select the printing device installed on your computer and change its current parameters.
- Using the *Area* field you can specify the print area – whole document, visible document part or rectangular window, which can be specified on the screen or by corners' coordinates.
- You can also specify scale, margins and paper alignment.
- Specify pages to print
- You can preview printing results on the screen.

turning off visibility of layers in the Layer Manager you can print only specified layers.

## WisImage Objects

**Brief description:** This section illustrates the different objects with which WisImage works – raster images and vector objects. Scanning, loading existing and creating new raster images. Creating vector objects, assigning and editing their properties. Creating user markers and symbols for floodfilling.

WisImage can simultaneously work with vector objects, raster images, and selected fragments of raster and hybrid graphics.

### Raster Images

You can scan raster images directly from the program, load existing images and create new raster images.

#### *Scanning with WisImage*

You can scan directly from WisImage, if you use a scanner provided with TWAIN-driver or a CONTEX scanner.

If several supported scanners are installed, choose one with the *Select Source* command of the *File* menu. Then start the *Acquire* command. The displayed dialog depends on the scanner and driver version. After scanning is finished, a new document with scanned images will be created.

If you want to scan an image and load it to the current document, use the *New Image from Scanner* command of the *Insert* menu.

For CONTEX and HP scanners special plug-in – WiseScan is also available. Read more about this feature in WiseScan documentation.

### ***Inserting raster images***

To insert a raster image to a new document, choose ***Open*** from the ***File*** menu.

To insert a raster image into the current document, choose ***Image*** from the ***Insert*** menu.

### ***Creating new raster images***

You can create a new raster image in the current document. Choose ***New Image*** from the ***Insert*** menu. Specify type, size, resolution and other properties for the new image in the ***New Image*** dialog. Press OK.

## **Vector Objects**

### ***Creating vector objects***

With WiseImage you can create different types of vector objects. The draw vector commands are located in the ***Draw*** menu and on the ***Draw*** toolbar.

You can specify point coordinates, angles and distanced when you create vector objects on the screen or enter their values in the corresponding fields of the ***Inspector*** window. While vector objects are being drawn the program status line (on lower-left corner) displays tooltips.

### ***Vector object properties***

Every vector object has a set of properties (belonging to a certain layer; color, line width and line type; markers, etc.) and geometry; which can be specified, viewed and modified in the ***Inspector***.

- Default properties of newly created vector objects are set according to the document's properties.

---

*For information on setting document properties see page 6*

- After creation, vector object properties can be changed in the ***Inspector*** (or the ***Properties*** toolbar). The next created object inherits the properties of the previous one.

The next created object will have the properties of the previously created one – if the ***Document Transparent*** radio button of the ***Properties mode*** section of the ***Inspector*** is on.

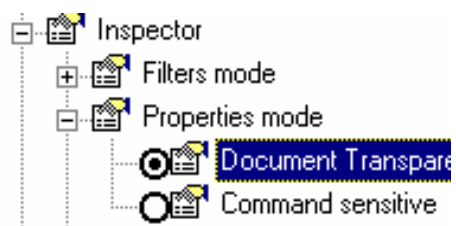

The next created object will have the default document properties, if the ***Command sensitive*** radio button is chosen.

The created vector object can inherit properties of the layer, on which it is created, if you specify ***By Layer*** in the

corresponding fields.

---

*See section Layer Manager on page 8 for information on layers.*

Vector objects included in a block can inherit the block properties, if you specify **By Block** in the corresponding fields.

### **Basic vector objects**

The commands used for creating vector objects are located in the **Draw** menu or in the **Draw** toolbar.

**Point** – is created by specifying on the screen or entering its coordinates in the corresponding fields of the **Inspector**

**Line** – is created by specifying two points or angle and length

**Arc** – is created by specifying three points; or center, start and angle, or by center, angle and radius

**Circle** – is created by specifying center and radius; or diameter; or three points

**Ellipse** – is created by specifying center and radiuses; or diameter and radius; or elliptic arc

**Elliptic arc** - is created by specifying center, radiuses and angles

**Rectangle** – is created by specifying three points or two opposite corners

### **Polyline**

You can create a polyline, which consists of line and arc segments. To draw an arc segment press the SHIFT key. To complete drawing a polyline choose the command **End Polyline** from the context menu, which appears if you right-click when drawing a polyline. The commands of the context menu also allow closing polyline and undo the latest drawn segment.

---

*See section Editing Vector Polyline on page 33 for information on editing polyline.*



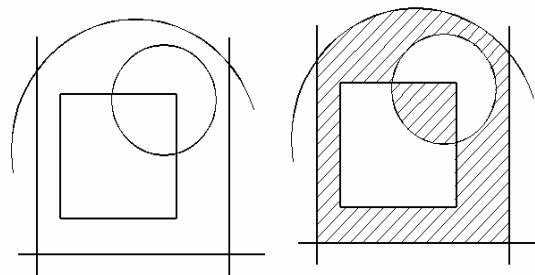

### **Hatch**

A hatch is created in a closed area, limited by vector entities (entity). The program hatches inward from the outer boundary. If it encounters an internal intersection, it turns off hatching until it encounters another intersection.

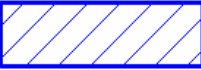

Thus, areas separated from the outside of the hatched area by an odd number of intersections are hatched, and areas separated by an even number are not. How to create hatch. Select objects – hatch boundary and start the **Hatch** command of the **Draw** menu.

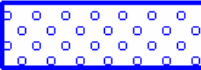
**Hatch types:**

			
Hatch Fill	Cross Fill	Shape Fill	Solid Fill

Hatch Fill and Cross Fill are characterized by line width, step (distance between lines) and skew angle.

Shape Fill is characterized by the shape, distance between shapes (or hatch step) and skew angle of lines, along which hatch shapes are placed.

You can set the hatch type in the *Inspector*.

A closed vector object (rectangle, circle, closed polyline) can have the *Fill* property.

**How to fill a closed vector object.** Select a closed vector object and in the *Inspector* set *Fill* to *True*, after that you can choose a fill type and properties in the corresponding fields that will appear.

### *Text*

**How to enter text.** Choose the *Text* command from the *Draw* menu. Texts are entered from the keyboard. The entered text string is completed by pressing ENTER.

The entered text parameters correspond to the default, set up in the document.

---

*See page 6 for information on setting document properties.*

You can also edit text parameters in the *Inspector* or the *Font* dialog.



You can open the *Font* dialog by pressing the  button, which appears if you click in the *Text Font* field of the *Inspector*.

### *Multiline text*

You can create, import and save multiline texts.

**How to create multiline text.** Choose the *Multiline Text* command from the *Draw* menu. Enter text in the window. Press OK. Insert the text in the document by specifying the insertion point.

---

*See section Vector object properties on page 18 for information on Multiline text properties.*

**How to import multiline text.** Press *Load*  of the *Edit multiline text* window. Select and open the \*.txt text file. Specify an insertion point for this text in the document on the screen or in the *Base Point* field of the *Inspector*.

**How to export multiline text.** Choose *Multiline Text*. Open the *Edit multiline text* dialog. Press the *Save*  button.

## Dimensions

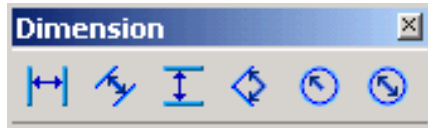

With WiselImage you can create the following dimensions: linear – vertical, horizontal and aligned; angular, radial and diametral

You can create a dimension object to specify distance and angle, radius and diameter of vector and raster objects.

### How to create dimensions

#### Method 1

1. Select an object to create dimension.

---

*See section Selection on page 23 for information on object selection*

2. Choose a corresponding button on the *Dimension* toolbar.
3. You can tune the dimension parameters in the *Inspector* – while rubber line for specifying dimension position is displayed.
4. Specify the dimension position on the screen by left-mouse click.
5. If needed, edit the position of dimension lines and text using grips.

#### Method 2

(You can use this method to specify all dimensions except angular dimensions between two lines.)

1. Choose the corresponding button from the *Dimension* toolbar.
2. Follow the next table instructions:

<i>For Dimension:</i>	<i>Specify on screen by click:</i>		<i>Specify on screen by click:</i>
Linear – Vertical, Horizontal and Aligned	Two points to measure distance between them	<b>Edit parameters in the Inspector toolbar</b>	Dimension line position
Angular	Vertex angle and its two sides		Angle – outer or inner and dimension arc position
Radial and Diametral	Arc center or circle center		Point on the arc (circle)

When specifying points you can use object snap to raster and vector objects.

---

*See page 13 for information on object snap*

3. If needed, edit the position of dimension lines and text by using the grips.

## **Blocks**

Block – is a named group of vector objects (block definition).

Unlimited number of blocks can be inserted in the document.

When inserting, you can rotate a block and change its scale.

Program supports unlimited block nesting (a block can not include itself).

You can create blocks with attributes. Attributes in blocks revolutionary ease the block management and collaboration with existing CAD formats.

When exploded, the block is broken into its component objects.

If you want to change all block insertion in the document, create a new block definition with the same name.

### **How to create block**

- Open the *Inspector* toolbar.
- Select vector objects.

---

*See page 26 for information on vector selection*

- Choose **Create Block** from the *Draw* menu.
- Enter a name for the block in the **Block Name** field of the *Inspector*.
- Enter the insertion point coordinates in the **Base Point** field or specify it on the screen.

### **How to insert block?**

- Choose **Block** from the *Insert* menu.
- Open the *Inspector*. Choose the block name from **Block Name** list of the *Inspector*.
- Enter the insertion point coordinates in the **Base Point** field or specify them on the screen.

### **Creating user markers**

You can create your own markers, which will be placed on the endpoints of such vector objects as lines, arcs and polylines.

How to create a new marker.

- Draw a marker of the desired shape. You can fill it with solid floodfill.
- Select the marker's elements.
- Choose the **Create Marker** command from the *Tools* menu.

- Press the button  in the open dialog box and specify a point to connect the marker to the line.
- Specify a name for the marker and save it by pressing **Save** or **Save As** button.
- The created marker appears in the lists of **Start Marker** and **End Marker** of the *Inspector*. It can be assigned to selected or

created vector objects.

### ***Creating shapes for floodfilling***

You can create your own shape to floodfill closed vector objects or Hatch objects.

**How to create a symbol for floodfilling.**

- Draw a shape for floodfilling. You can use solid floodfill to fill it.
- Select the shape.
- Choose the ***Create Fill Shape*** command from the ***Tools*** menu.
- Save the shape with name using ***Save*** or ***Save As*** button.
- The created shape appears in the ***Hatch Shape*** of the ***Inspector***. You can select it from the list when creating hatch or Shape Fill.

### **Raster Drawing Mode**

The Raster drawing mode enables you to draw raster representations of vector objects.



To turn on the raster drawing mode choose the RDRAW button, located in the right-lower screen corner.

There should be a raster image under the objects that you draw in raster drawing mode; otherwise the created objects will disappear.

### **Selection**

**Brief description:** To perform different operations – such as edit, modify an object’s properties with the Inspector, and others – you need to select data to apply commands to. In this section we consider raster and vector data selection technology. You will learn about different selection modes, methods of data selection, and tuning raster selection.

You can select raster, vector and hybrid (both raster and vector) data in WiselImage. Selection technology and data selection methods for all data types are extremely close to vector object selection technology.

WiselImage allows selection of the following data and their combinations:

- **Vector objects** (raster images are included)
- **Raster data:**
  - ***Raster objects*** (raster lines, arcs, circles, selected with object selection methods, which have “grips”, properties and precise geometry).
  - ***Area fragments*** of the raster image.
    - Selected with window or polygon.
    - Raster line segments of arbitrary shape. (A segment

represents part of a raster line of arbitrary shape, limited by points of intersection with other raster lines or endpoints).

- Isolated raster fragments.
- Hybrid data (both raster and vector data selected).

You can use the *Selection, More Selection and WiseObject Selection* toolbars to select data.

**IMPORTANT:** When selecting data, you need to define three parameters:

- Type of data to select – raster, vector or hybrid

*See section Type of Data Selected on page 24*

- Selection modes – add to selection, remove from selection, single selection.

*See section*

*Selection Modes on page 25*

- Selection method – by picking, within window, crossing polygon and others.

*See section Raster Selection Methods on page 25*















	Type of data selected	Selection mode
		
		
		
		
Selecting raster images from the list	Select by filter	Polyline editing mode
Vector selection	Raster selection	Hybrid selection
Raster area selection	Add to selection	Remove from selection
Single selection	Select (dependable on selection mode)	Deselect









Table 1. Type of data selected, selection modes

### Type of Data Selected

You need to define the type of data to select (raster, vector or hybrid) by pressing the corresponding button on the *Select* toolbar.

	To select vector objects and raster images, choose <i>Vector Selection</i>
	To select raster data, choose <i>Raster Selection</i>
	To select hybrid data, choose <i>Hybrid Selection</i>

## Selection Modes

	New data is added to selection	
	Selected data is removed from selection	
	Every new selection deselects previously selected data	
		Selects all vector objects in WiselImage document (except raster images)
		Selects the contents of all raster image in WiselImage document
		Selects all objects in WiselImage document (raster images are included).
	To deselect all selected data choose <i>Deselect All</i>	

## Raster Selection Methods









Select by picking	Select within window	Select within polygon	Select raster objects by reference object:	Select by picking	Select by picking	Select within window	Select within polygon	Select with crossing window	Select with crossing polygon	Select by fence	
<b>Vector object</b>	<b>Raster object</b>	<b>Raster line by 2 points</b>	<b>Raster arc by 3 points</b>	<b>Raster circle by 2 points</b>	<b>Raster symbol</b>	<b>Isolated raster area</b>					<b>Vector objects</b> <b>Raster objects</b>
							<b>Raster line segments</b> <b>Isolated raster areas</b>				

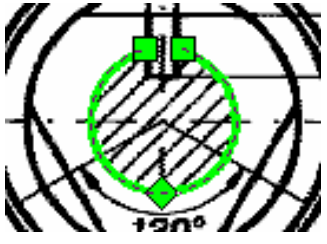

Table 2. Selection methods

## Object selection methods of vector and raster data

You can select vector and raster objects (raster lines, arcs, circles) using *object selection methods* (green buttons):

	By Picking (Auto)		By Crossing Window	
	Within Window		By Crossing Polygon	
	Within Polygon		By Fence	

You can also select raster objects *by reference objects*:

	raster line or its segment by 2 points		raster arc or its fragment by 3 points		raster circle by two points
---	--	---	--	---	-----------------------------

### How to obtain the raster area selection using object selection methods

**IMPORTANT:** If you need to obtain an area selection when selecting raster objects press



*Raster Area Selection*, located on the *Select* toolbar.

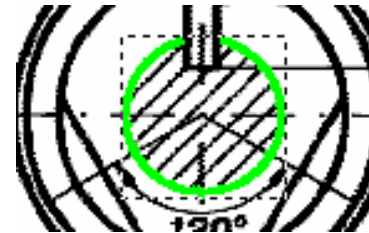

### Raster Image Selection

If you need to select the raster image, specify (cross) its frame, choosing vector (hybrid) type of data selection.

If the document contains several raster images and you need to select some of them use *Select Raster* on the *Select* toolbar.



Choose *Select Image* button, located on the *Select* toolbar

- Select desired raster images from the list
- Close the *Select Raster* window

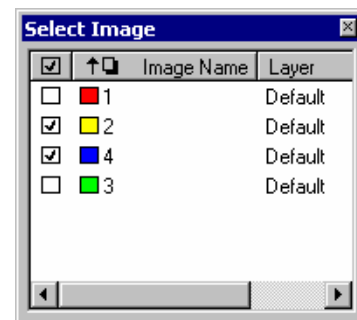

### Selecting raster area fragments

#### Selecting inside rectangle or polygon

You can select rectangular or polygonal fragments of the raster image area using *Select by Rectangle* or *Select by Polygon* button, located on the *Select* toolbar. You can select:

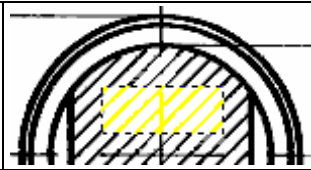
	rectangular fragment of raster image		polygonal fragment of raster image	
---	--------------------------------------	---	------------------------------------	---

### Selecting raster segments

Segment represents part of a raster line of arbitrary shape,

limited by intersection points with other raster lines or endpoints.

You can select raster line segments (blue buttons):

	Within window		By window crossing	
	Within polygon		By polygon crossing	
			By fence	

### Selecting isolated raster fragments

You can select isolated raster objects (red buttons):

	By picking		By crossing window	
	Within window		By polygon crossing	
	Within polygon		By fence	

## Tuning Raster Selection

You need to tune the geometry of raster data to obtain the best results when selecting raster objects and raster segments.

How to tune the raster selection.

The selection geometry is tuned using the *R2V Conversion Options* dialog or *Raster Properties* toolbar. To open this dialog, choose *Conversion Options* from the *Convert* menu.

Specify the following values in the *Options* tab:

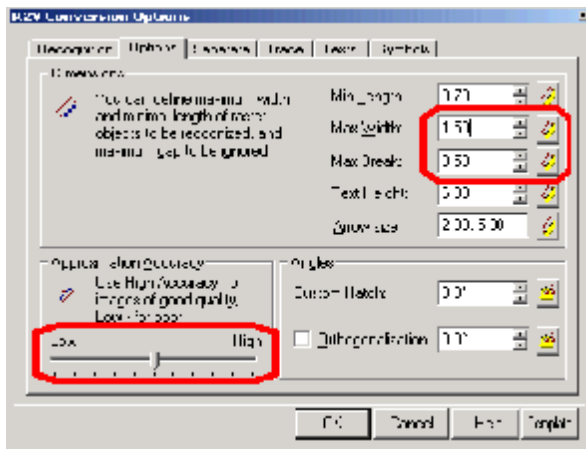

**Max. Width** – maximum width of raster object to select. Specify this parameter value slightly greater than maximum width of raster objects or raster line segments.

**Max. Break** – length of ignored break in raster lines.

**Accuracy** – your document accuracy. For example, if when selecting a raster circle by picking, the program only selects its fragments (arc), reduce the accuracy value.



## Filter for Data Selection

You can select data, grouping them by type, color, and layer.



To select a group of objects, choose **Select Objects with Filters** button on the Select toolbar.

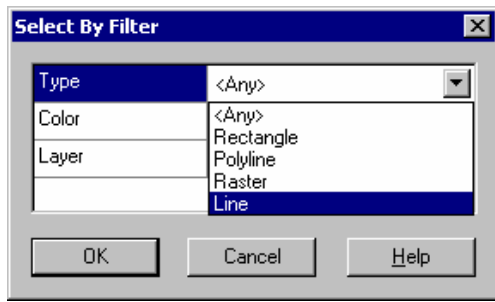

- Select a desired object type from the **Type** list

**Type** includes only those types of objects, which are contained in the document.

- You can group objects of a selected type by color and layer.

## WiseObject Selection

The brand new selection engine, called **WiseObject** selection tool added with its new toolbar. This tool allows you to select all text areas and hatches as well as speckles and linear objects with the new advanced method.

You can select hatches, linear objects, text areas and speckles

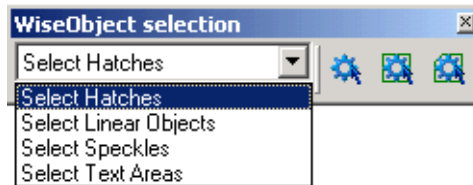

	All the indicated objects in the current image will be selected
	You can select the indicated objects within window
	You can select the indicated objects within polygon

## Editing Wisel mage Objects

**Brief description:** In this section you will learn different methods of editing selected data – raster, vector and hybrid, and also the commands designed for editing raster images and vector objects, including vector polylines.

### Editing Data, Selected with Object Selection

If you select data with the object selection methods:

- You can view and edit the properties of objects using **Inspector**.

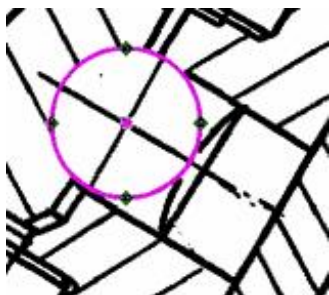

*Selected object*

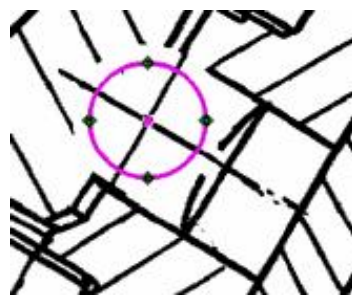





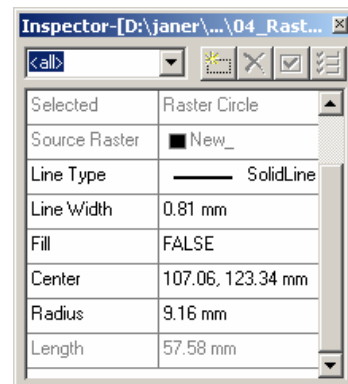









*Modified object*

The raster object properties in the Inspector



- You can change the geometry of raster and vector objects and also the location of selected objects on screen using “grips”.
- You can apply the following edit commands to selected objects: The commands are located in the *Modify* and *Correct* menu.

<i>Edit commands:</i>		<i>You need to specify:</i>
	Move	<ul style="list-style-type: none"> <li>• Shift – by 2 points on the screen or in the <b>Shift</b> field of the <b>Inspector</b>.</li> </ul>
	Copy	<ul style="list-style-type: none"> <li>• A number of copies – in <b>Copy</b> field of the <b>Inspector</b>.</li> <li>• Distance between copies – by 2 points on the screen or in the <b>Shift</b> field of the <b>Inspector</b>.</li> </ul>
	Duplicate	
	Rotate	<ul style="list-style-type: none"> <li>• A number of copies– in the <b>Copy</b> field of the <b>Inspector</b>. Specify “0” to set no copies.</li> <li>• Rotation center (if it differs from the selection geometric center) and rotation angle –on the screen or enter the values in the corresponding fields of the <i>Inspector</i>.</li> </ul>
	Scale	<ul style="list-style-type: none"> <li>• A number of copies– in the <i>Copy</i> field of the <i>Inspector</i>. Specify “0” to set no copies.</li> <li>• A base point by which to scale (if it differs from the selection geometric center).</li> <li>• Scale factor – in the <i>Scale</i> field of the <i>Inspector</i> or specify a base distance and desired distance on the screen. Distances are specified between the base and reference points.</li> </ul>
	Mirror	<ul style="list-style-type: none"> <li>• A number of copies– in the <i>Copy</i> field of the <i>Inspector</i>. Specify “1” to keep the original object, “0” – to delete it.</li> <li>• Mirror line – directly on the screen or by specifying the first point and angle for the mirror line in the corresponding fields of the <i>Inspector</i>.</li> </ul>
	Flip Horizontal	
	Flip Vertical	

	Align	<ul style="list-style-type: none"> <li>• A number of copies– in the <i>Copy</i> field of the <i>Inspector</i>. Specify “1” to keep the original object, “0” – to delete it.</li> <li>• The first source and destination points.</li> <li>• The second source and destination points.</li> </ul>
	Array	<ul style="list-style-type: none"> <li>• A number of Rows и Columns in the corresponding fields of the <i>Inspector</i>.</li> <li>• The angle of array rotation relative to the X-axe in the <i>Inspector</i> or on the screen (if needed).</li> <li>• The distance between Rows and Columns – in the corresponding field of the <i>Inspector</i> or directly on the screen.</li> </ul>
	Duplicate by vector	<ul style="list-style-type: none"> <li>• A number of copies– in the <i>Copy</i> field of the <i>Inspector</i>.</li> <li>• The insertion point for the duplicated object (if it differs from the selection geometric center).</li> <li>• The vector object along which copies will be placed – on the screen.</li> </ul>
<b>Edit commands:</b>		<b>Executive order:</b>
	Correct to intersection	<ul style="list-style-type: none"> <li>• Select objects to edit, and then start the command.</li> <li>• Move cursor to a pair of vector objects. If you are satisfied with the rubber line position, press the left mouse button.</li> </ul>
	Offset	<ul style="list-style-type: none"> <li>• Offset Distance in the corresponding field of the <i>Inspector</i> toolbar.</li> <li>• Offset position (inside or outside) – on the screen</li> </ul>
	Create Chamber	<ul style="list-style-type: none"> <li>• Select objects to edit, and then start the command.</li> <li>• Choose the way to create Chamber in the <i>Inspector</i>– by either two distances or one distance and angle.</li> <li>• Enter the command parameters (distances, angle) in the corresponding fields of the <i>Inspector</i>.</li> <li>• Moving cursor, choose the right position for the rubber line and press the left mouse button.</li> </ul>
	Create Fillet	<ul style="list-style-type: none"> <li>• Select objects to edit, and then start the command.</li> <li>• Specify a radius for the Fillet in the corresponding field of the <i>Inspector</i></li> <li>• Moving the cursor, choose the right position for the rubber line and press the left mouse button.</li> </ul>

	<p>Align Angle and Distance</p>	<ul style="list-style-type: none"> <li>• Select objects to edit, and then start the command. Set in <b>Inspector</b>.</li> </ul> <p>To align angles between the lines:</p> <ul style="list-style-type: none"> <li>▪ AutoResizing – FALSE, Distance – “0”</li> </ul> <p>To align angles and specify a distance between the lines:</p> <ul style="list-style-type: none"> <li>▪ AutoResizing – FALSE, enter a desired value in the <b>Distance</b> field</li> </ul> <p>To align angles and distance between the lines:</p> <ul style="list-style-type: none"> <li>▪ AutoResizing – TRUE</li> </ul> <ul style="list-style-type: none"> <li>• Move the cursor to the line, relative to which you want to align the others. If you are satisfied with the rubber lines position, press the left mouse button.</li> </ul>
---	---------------------------------	---

## Editing Vector Objects

### *Trim, extend, break vectors*

You can use the following objects as a cutting edge – for trimming, extending, or breaking vector objects:

- Vector or raster object;
- Pre-defined Edge.

**In case you use a vector or raster object as cutting edge:**

1. Select the object(s) you want to use as cutting edge.

---

*See page 26 for information on raster and vector selection*

2. Choose the command – trim, extend or break from the **Correct** menu or on the **Vector Correction** toolbar.
3. Specify the vector objects one by one to apply the command to.

**In case you use pre-defined Edge as cutting edge:**

Define *Edge*

- Select vector objects to form Edge.
- Choose **Group/Ungroup Edge** command from the **Correct** menu.

1. Select vector objects to edit
2. Choose the command – trim, extend or break from the **Correct** menu or on the **Vector Correction** toolbar.

## Editing Raster Images

The commands from the **Image** menu are designed for editing raster images.

The commands from the **Image** menu modify the raster image contents – resolution, real size, size in pixels, points' positions.

**IMPORTANT:** You should know the difference between the editing

commands of *Modify* menu (see section on page 28), and those of the *Image* menu.

Unlike the commands of the *Image* menu, the commands of the *Modify* menu do not change the raster image contents. For example:

- The *Scale* command of the *Modify* menu only changes the scale of raster display in the document; the raster image contents (resolution, number of points and location), is the same.
- Using the *Scale* field of the *Resample* dialog box, you can modify the raster image contents – resolution and/or the number of points the image is composed of.

### *Change image size*

Choose *Change Size* from the *Image* menu.

Using the *Change Size* dialog box you can:

- Change the image size to the desired format.
  - Choose the desired format from the list of *Standard Paper Size*. Set orientation – *Portrait* or *Landscape*.
- Change the image size to the closest standard format.
  - Press the *Find Closest* button.

---

*You can edit the list of standard formats using the Preferences dialog box. See section Customizing Program Parameters on page 80.*

- Add (cut) image margins.
  - Specify values to add (cut) margins in the *Alignment/Margins* section.

You can also align the image position relative to its margins:

- Using one of the nine buttons of the *Alignment/Margins* field.
- Entering the margins values in the *Alignment/Margins* section with the *Fixed Size* checkbox set to on.

### *Resample*

Choose *Resample* dialog from the *Image* menu. Using the *Resample* dialog you can:

- Proportionally change the image size with fixed resolution.
  - Choose measurement units from the list; you can choose pixels as measurement units.
  - Enter the new values in the *Width* and *Height* fields.
  - The *Fixed size in pixels* checkbox is off.
- Change the image size according to specified Scale value with fixed resolution.
  - Enter the new scale value to the corresponding field.
  - The *Fixed size in pixels* checkbox is off.
- Change the image resolution with fixed size.

- Enter the new resolution value to the corresponding field.
- The *Fixed size in pixels* checkbox is off.
- Change the image resolution (size) with fixed number of pixels.
  - Select the *Fixed size in pixels* checkbox.
  - Enter the new resolution (size, scale) value.

### ***Cropping image***

Cropping commands are located in the *Crop* submenu of the *Image* menu.

You can:

- Crop blank margins of the raster image.
- Crop the raster image by its frame.
- Crop the raster image by a rectangle specified on the screen.
- Crop the raster image by pre-defined clip.

---

*Information on Image Clip is provided on page 15.*

### ***Rotate and mirror***

These commands located in the *Image* menu, allow you to rotate an image by 90<sup>0</sup>, 180<sup>0</sup>, 270<sup>0</sup>, or by an arbitrary angle; and also mirror an image about X-axis or Y-axis.





---

*The other commands for editing raster images are provided in section Enhancing Scanned Images on page 34*

## **Editing Vector Polyline**



The polyline editing commands are located on the *Edit Polyline* toolbar, and also in the context (right-button) menu. Select a polyline to edit.





You can apply the following commands:

	Close polyline by joining end nodes
	Close polyline with a new segment, which connects end nodes
	Add a new vertex at a specified point
	Break polyline at a specified point or node

 The following operation requires the selection of polyline nodes. For this, you need to press the ***Node Selection*** button of the ***Select*** toolbar.

Now you can select polyline nodes by mouse click.

	To delete a polyline node, select it and press the <b><i>Delete node</i></b> button
	by connecting specified end nodes with linear segment

	by connecting specified end nodes with arc segment
	by joining specified end nodes
	Transforming a specified arc segment to a linear segment. To specify a segment, click on its first node; nodes are numerated from the polyline start.
	Transforming a specified linear segment to an arc. To specify a segment, click on its first node; nodes are numerated from the polyline start.

## Search and Replace

Search and replace operations allow you to:

- Find raster fragments and replace them with other fragments or vector objects.
- Find vector objects (which can consist of lines, arcs, circles, and polylines) and replace them with other vector objects.

How to perform search and replace

- Choose ***Search - Replace*** from the ***Edit*** menu.
- Define a sample for searching – raster or vector fragment, and then place it in the ***Find What*** field of the ***Search - Replace*** dialog box.
- Define a sample for replacing – raster or vector, if you search for raster fragment; and only vector, if you search for vector fragment.
- Set the accuracy value. The position of the ***Accuracy*** slider defines the deviation of found objects from the sample for searching.
- Select the ***Erase*** checkbox to erase original elements.
- Select the ***Only Standalone Symbols*** checkbox to search for only standalone raster objects or vector symbols.
- Press the ***Find*** button to search and replace symbols one by one. Press the ***Replace All*** to search and replace symbols in automatic mode throughout the entire document.

## Enhancing Scanned Images

**Brief description:** This section demonstrates ways of enhancing scanned monochrome images – deskewing, filtering, and eliminating distortions using calibration and four-point correction. Also, we give you some recommendations about restoring poor quality images.

### Deskewing

When paper is fed through a scanner the direction of the paper often deviates from the orthogonal, therefore the resulting scanned image is skewed, sometimes rather considerably.

The special command – *Deskew* is used to deskew an image.

The command works in two modes:

1. **Auto Deskewing** – program automatically estimates the skew value, and then performs deskewing.

Choose *Deskew* from the *Image* menu, and then –*Auto*

2. **Manual Deskewing** – you can use this mode, if the result of Auto Deskewing is not satisfactory. In this mode you can specify a skew angle by specifying a line, which must be horizontal or vertical.

Choose *Deskew* from the *Image* menu, and then –*Manual*.

Press the *Measure Angle* button in the displayed dialog, and then specify the deskew line with two points. You can use snap tools during this operation.

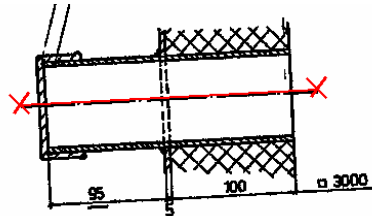

*Manual deskewing*

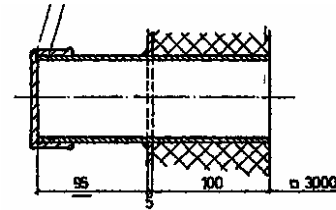

*After deskewing*

## Filtering Monochrome Images

There are a number of different filters available within WiselImage, which allow you to considerably enhance the scanned monochrome raster image. You can apply filters to the whole image or to a fragment. You can also apply filters to several raster images simultaneously.

Using the filters, you can:

- Remove raster speckles
- Remove holes (white points in black raster lines or filling)
- Invert images
- Smooth raster objects
- Thin and thicken raster objects
- Transform filled raster area to one-pixel contour

All commands for filtering monochrome images are located in the *Filters* menu.

### *Speckle Remover*

Choose *Speckle Remover* from the *Filters* menu.

You can specify the size of raster speckle on the screen using the measure buttons of the *Speckle Remover* dialog.

If the **Auto Estimating** checkbox is on, the program automatically estimates the speckle size. You can apply the filter several times.

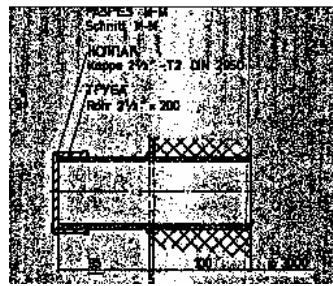

Before applying Speckle Remover

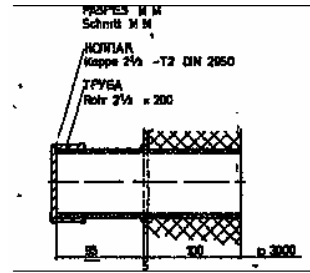

The result of applying Speckle Remover

When applying the filter to the image of very poor quality some data may be lost. To avoid it, you can use the operation of Separation by size.

See page 38 for information on separation by size for the monochrome image.

### Hole Remover

Choose **Hole Remover** from the **Filters** menu. You can specify the size of raster speckle to remove on the screen using the measure buttons of the **Hole Remover** dialog box.

If the **Auto Estimating** checkbox is on, the program automatically estimates the speckle size.



Before applying Hole Remover



The result of applying Hole Remover

### Inversion

Choose **Inversion** from the **Filters** menu

This filter reverses the color of the monochrome image: After applying this filter the background dots become the image dots and vice versa.

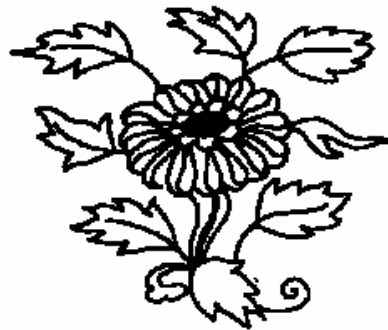

Before applying Inversion

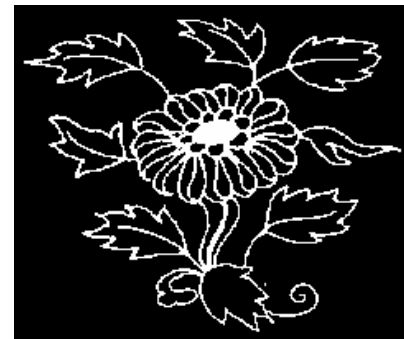

The result of applying Inversion

### Smoothing

Choose **Smoothing** from the **Filters** menu

This filter smoothes raster object outlines, fills edge and inner background droplets, and partially

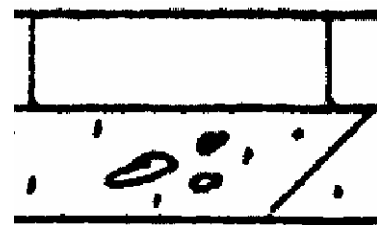
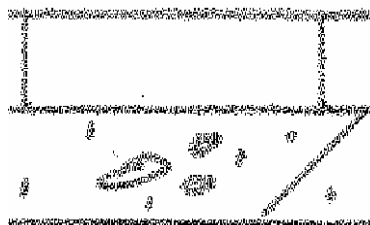

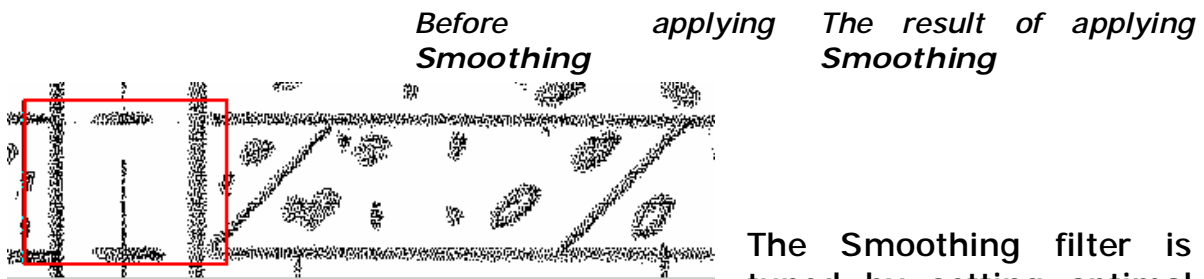

The Smoothing filter is tuned by setting optimal values of Medianning and Threshold. You can estimate the result before applying the filter in the preview window.

*Tuning Smoothing filter*

### **Thinning and Thickening filters**

Choose **Thinning (Thickening)** from the *Filters* menu

**Thinning** filter makes raster objects thinner in the specified directions; by one pixel for one pass. You can specify a number of passes.



*Before applying The result of applying*  
**Thinning Thinning Thinning**

If needed, you can apply the mode of thinning raster objects up to skeleton – i.e. only pixels in the middle are left.

**Thickening** filter makes raster objects thicker in the specified directions. You can specify a number of passes and choose any combination of thickening directions.

### **Contour (4-coupling and 8- coupling)**

Choose **Contour** from the *Filters* menu

Contour filters convert filled raster areas to one-pixel contours.



*Before applying Contour*



*The result of applying Contour*

## Separating Monochrome Images by Size

This operation is effective in the following cases:

- If you want to prevent important small objects from being removed while applying the Speckle Remover filter (e.g., dots in dashed-dotted lines; lines which consists of multiple small fragments, delimiters, etc).
- If you work with an image of very poor quality.

The principle of the separation by size operation is similar to speckle removing, except speckles are not removed but transferred to a new raster layer; and then the user can select fragments incorrectly transferred to this "speckle" layer and bring them back to the drawing.

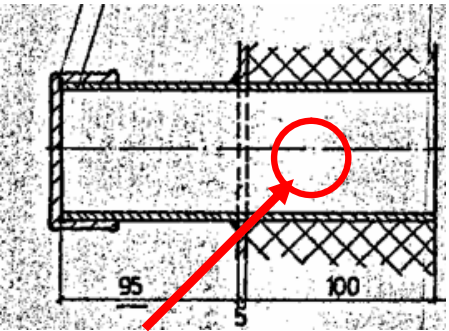

Original image

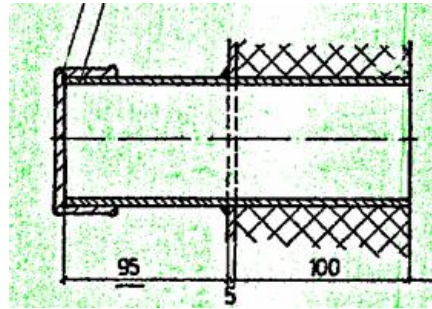

The result of separating to basic and "speckle" layers

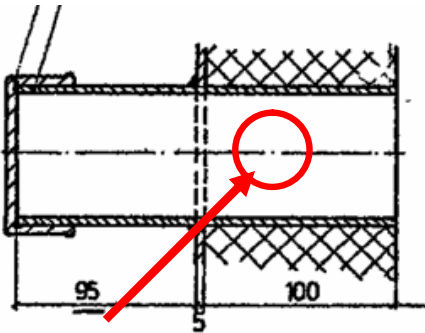

*The significant elements have been brought back from the "speckle" layer to the basic layer; the "speckle" layer is removed*

## Eliminating Distortions Using Calibration

**Calibration** – is applied to eliminate arbitrary (both linear and non-linear) distortions of monochrome, grey-scale and color raster images.

**IMPORTANT:** You should calibrate the raster image before vectorization (tracing), because if you vectorize a distorted image you will obtain distorted vector data that is impossible to correct later.

### Calibration terms

The original image must contain points with known coordinates. These points are called *real* points. You can use nodes of a rectangular grid as real points (if you work with mapping materials) and/or other points, which coordinates are known or can be calculated.

The points, which correspond to the real ones on the distorted image, are often located with some displacement (i.e. they have different coordinates). These points are called *measured* point, as their

coordinates value can be measured on the raster image.

By applying calibration, the raster images is transformed so that the measured points coincide with or are extremely close to the real points.

before applying calibration you should set the User Coordinate System by specifying its origin and scale.

---

*See section Document Coordinate System on page 7 for information on setting Uses Coordinate System.*

### ***How to calibrate an image***

Choose ***Calibration*** from the ***Image*** menu.

#### **Step 1. Defining real points**

We can define rectangular grid nodes and points with known (estimated) coordinates.

***Defining grid:*** Grid is defined by the three parameters: start point (coordinates of lower-left node), cell size (by X and Y axis), and grid size (by X and Y axis).

- Press ***Define Grid***  on the ***Calibration*** toolbar. In the ***Calibration Grid*** dialog:
- Specify the coordinates of the lower-left grid node in ***Origin***.  
You can enter the coordinate values of the lower-left grid corner in the corresponding field or specify it with the cursor on screen.
- Enter the number of grid cells along X and Y axis in ***Size*** field.
- Enter the cell size along X and Y axis in ***Cell*** field.
- If the grid is rotated about the coordinate axis, enter the skew angle relative to X-axis in ***Angle*** field.

Use the ***Preview*** button to make sure that the grid is properly specified.

#### ***Specifying points with known coordinates:***

- Press ***Add point***  button from the ***Calibration*** dialog. Enter the point's known coordinates in ***Real*** field (use separating character between X and Y values). You can enter a name for the point in ***Label*** field; alternatively the program numbers the points consecutively.
- Do the same for all points.

#### **Step 2. Specifying measured points**

To begin step 2 you can press ***Next Point*** . WiselImage places the first point from the list in the screen center and highlights it with grips.

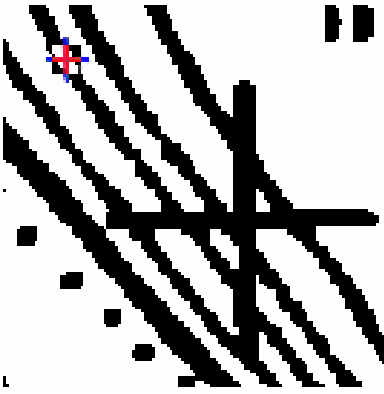

You see the real (correct) coordinates of the first point with grips.

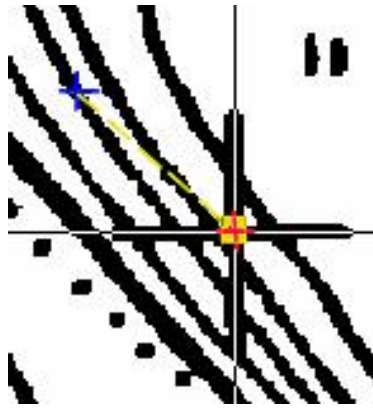

Drag grips to the grid node on the scanned image – so you specify the “measured” point.

To shift to the next (previous) point, use *Next (Previous) point*.

You can also use the acceleration keys: N (Next) or Tab – to shift to the next point and P (Previous) – to the previous.

### Step 3. Choosing calibration method

Choose the optimal method from the pull-down list of *Calibration Method* field.

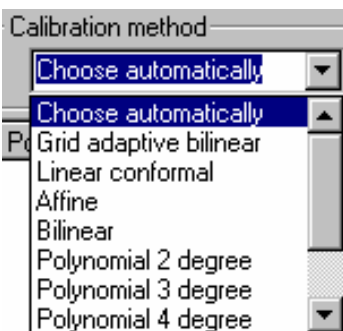

#### What method to choose?

- If you are sure of the proper method, choose it from the list. Estimate the accuracy of this method by pressing *Estimate*  button.
- If you are not sure of the proper method, select *Choose automatically* from the combo-box of the calibration method.

### Step 4. Running Calibration

- If you have several raster images in your document, select one(s) that need calibrating using the specified set of calibration pairs.

---

*See page 26 for information on raster image selection.*

- Run calibration by pressing the *Apply* button.

#### Four-Point Correction

You can use this operation for quick correction of scanned technical drawings, which contain a frame. This operation assumes that both frame and contents of the image have the same distortion.

#### How to correct an image by 4 points.

- If you have several raster images in your document, select the one to calibrate by four points.

---

*See page 26 for information on raster image selection.*

- Choose *4 point correction* from the *Image* menu.

- Enter the frame size in the *Width* and *Height* fields of the *4 point correction* dialog. You can also choose a standard frame size from the list of *Frame Size* or find the closest by pressing *Find Closest paper*.

---

*The list of standard formats is set in the Properties dialog. See information on page 80*

- Press *Find Frame*  – the program finds and highlights the image frame.

*If the frame is defined correctly:*

- Press OK.

*Alternatively:*

- Press *Measure frame*  button, and then specify four points of the frame on the screen.
- Press OK.

## Autocorrecting Image

Autocorrect runs a set of predefined operations.

How to apply autocorrection.

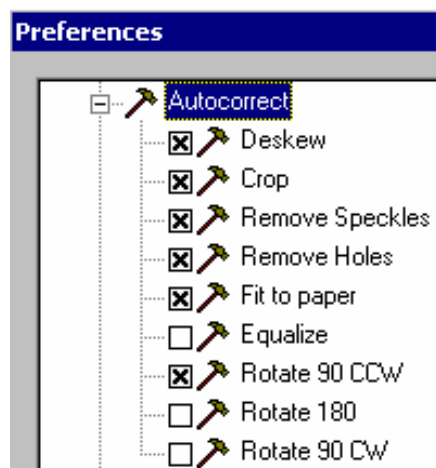

- Choose *Preferences* from the *Tools* menu.
  - Specify a set of commands to apply with autocorrection using the *Preferences* dialog. Close *Preferences*.
  - If you have several raster images in your document, select the one(s) to apply autocorrection to.
- 
- See information on raster image selection on page 26.*
- Choose *AutoCorrect* from the *Image* menu.

The parameters of the commands included in the autocorrection list (except *Rotate*) are automatically defined. For example, deskewing with auto definition of rotation angle, removing speckles with auto definition of speckle size, etc. If you want to specify the parameters of executed commands precisely, use the batch process.

---

*See information on batch process on page 76.*



## Editing Raster Text

You can edit raster texts –original text under the defined rectangle is erased and replaced with new text.

- From the *Draw* menu, choose *Raster*, and then *Edit Raster text*.
- Draw a frame over the text to be modified.

While drawing, you can specify the frame angle in the corresponding field of the *Inspector*.

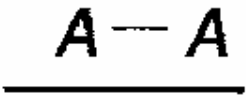
- Enter new text in the Text field of the *Inspector*. You can set text parameters in the corresponding fields of the *Inspector*.

		
<i>Original raster text</i>	<i>Selected text area</i>	<i>After editing</i>

## Restoring Images of Poor Quality

How to work with a raster image of very poor quality.

There isn't much choice – either redraw it in the document with the corresponding program, or restore it with a hybrid editor (vectorization of such document produces poor results).

*The purpose of this section* is not to discuss the plus and minus points of these choices, but to provide you with some methods to restore scanned documents of poor quality.

- Separating an image by size – can be used for blueprints, images on dark backgrounds, with lots of speckles.

---

*Information on separating image by size is provided on page 38.*

- Editing selected raster objects (modifying their properties, geometry using «grips» and others.)

---

*Information on editing selection is provided on page 28.*

- Tracing in smooth mode.
- Tracing in vector producing mode. Editing and rasterizing the obtained vector object.

---

*Information on tracing is provided on page 55.*

- Drawing missing raster lines in Raster drawing mode.

---

*Information on Raster drawing mode is provided on page 23.*



- Editing raster texts

---

*Information on editing raster texts is provided on page 41.*

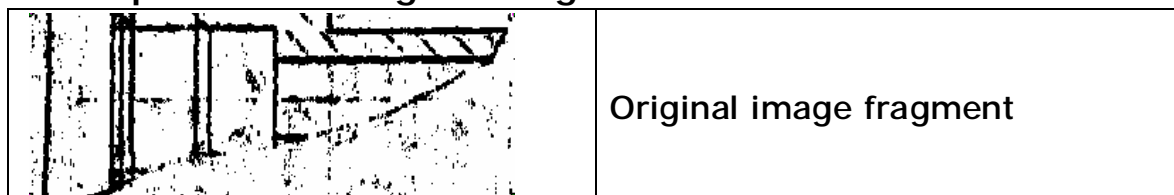
**Example of restoring an image**

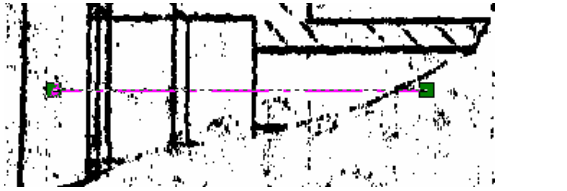
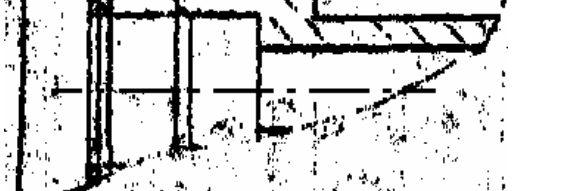

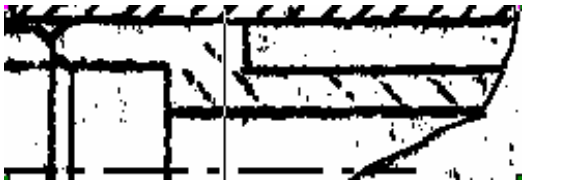
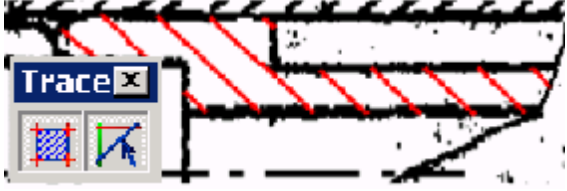
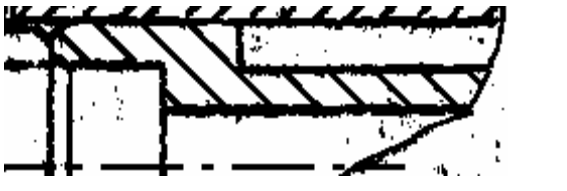
	Choosing and editing the axe line
	Result of editing the axe line
	Tracing the curve in smooth mode
	Hatch on the original raster image
	Tracing the hatch in Create Vector and Erase Raster mode
	Rasterizing the vector hatch

Then you can apply the following actions:

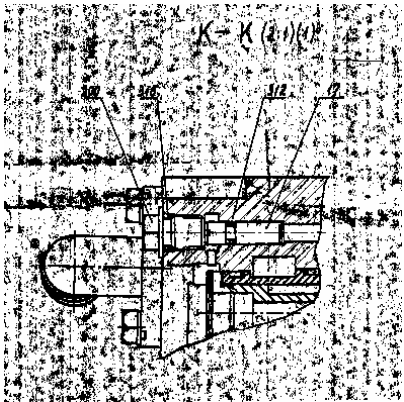
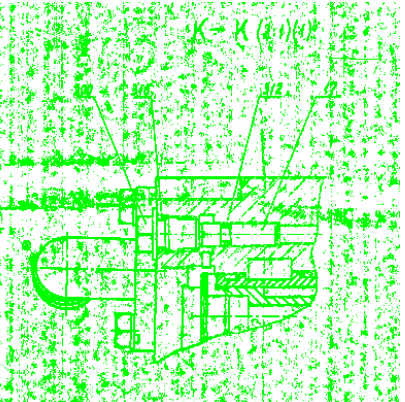
	
<i>Edited raster image</i>	<i>Selecting the whole raster image (or fragment)</i>

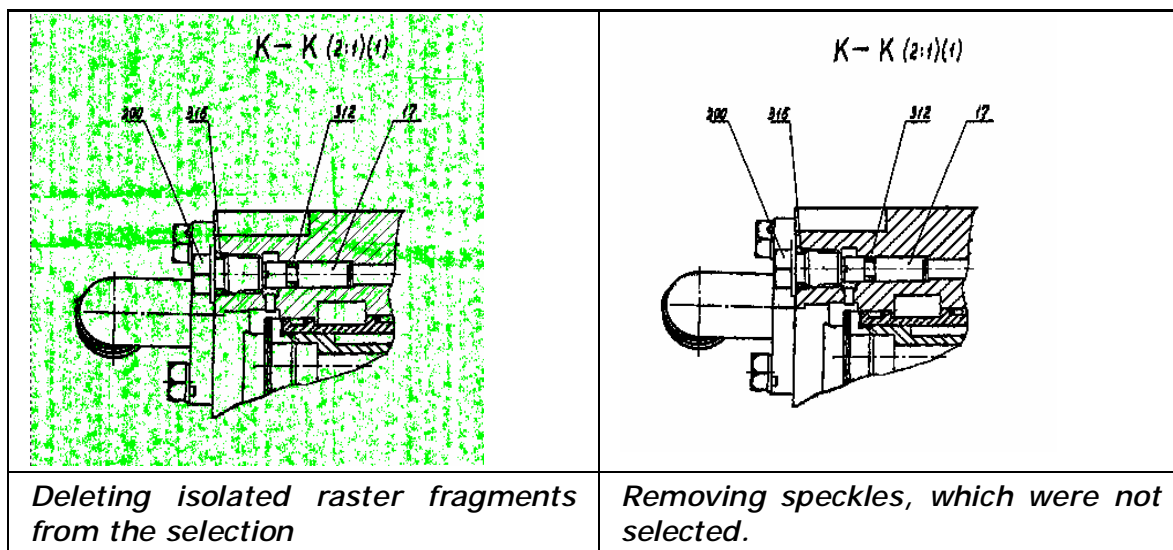

## Editing Color Images

**Brief description:** This section is devoted to methods of enhancing color and greyscale raster images – correcting image brightness, contrast, hue, and saturation; correction by histogram, and filtration. You will also learn about converting images to RGB, 8-bit indexed and greyscale; layering color and greyscale images to monochrome layers.

### Correcting Image Brightness, Contrast, Hue, and Saturation

You can tune brightness, contrast, hue and saturation of color and greyscale images.

Choose *Brightness/Contrast* from the *Image* menu.

Using *Brightness/Contrast* dialog, you can tune:

- Brightness of color and grayscale image
- Contrast of color and grayscale image
- Hue of color image
- Saturation of color image

You can tune the parameter value using the sliders or entering the values in the corresponding fields.

### Correction by Histogram

Using correction by histogram you can tune the image brightness, hue and contrast. You can apply automatic correction by histogram or tune the parameters manually.



Choose *Equalize* from the *Image* menu.

To correct an image by histogram automatically, press the *Auto* button of the *Equalize* dialog.

To correct an image manually you need to specify three values:

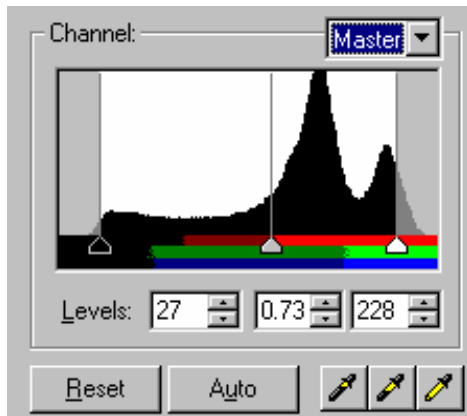
lightest and darkest levels, and image gamma – for each channel or for Master channel.



- darkest level (the left slider position) is set using the dark eyedropper , using which you can specify the colors to turn black. All pixels included in the histogram area from 0 to the left slider, will turn black.
- lightest level is set using the light eyedropper , using which you can specify the colors to turn white. All pixels included in the histogram area from the right slider to 256, will turn white.

- Using the middle slider, specify the value of image gamma.

Moving the middle slider to the left increases the gamma value; the image becomes lighter.

Moving the middle slider to the right reduces the gamma value; the image becomes darker.

- When you achieve satisfactory results in the Preview window, press the **Apply** button.

## Color Filters

### **Blur**

This filter produces a blur effect on an image. For example, you can apply the Blur filter to an image which has texture fills.

Choose **Blur** from the **Filters** menu.

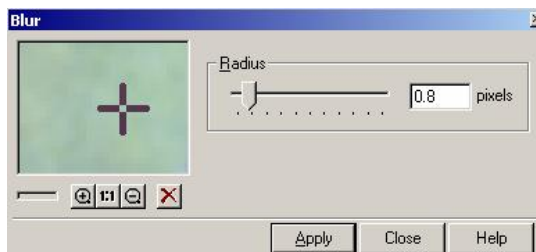

- Set **Radius** for the filter. Increasing the radius value also increases image blurring. To modify the Radius value use the slider or enter the value in the field.
- When you achieve satisfactory results in the Preview window, press the **Apply** button.

### **Adaptive Blur**

This tool is designed for blurring not uniform color areas inside the color transition boundaries in the image. It works on grayscale and color images.

The blurring makes an impression that an image is slightly «out of focus».

The **Adaptive Blur** filter in contrast to the **Blur** filter tries to recognize color transition boundaries in the image and leave them unchanged, without smoothing.

Start the command **Adaptive Blur** from the **Filters** menu.

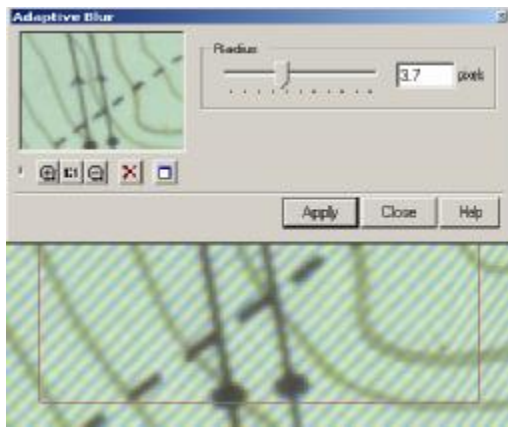

- Sets the *Radius* value, which determines the depth (in pixel) of the filter effect on the color area.
- When you achieve satisfactory results in the Preview window, press the ***Apply*** button.

### ***Unsharp Mask***

This filter is designed to increase the sharpness of color boundaries, producing an overall increase of image sharpness. For example, this filter can be used to correct images that became blurred after interpolation – e.g., after such operations as *rotate*, *scale*, *alignment*, *calibration* or *four-point calibration*, and also resize and resample.

Choose ***Unsharp Mask*** from the ***Filters*** menu.

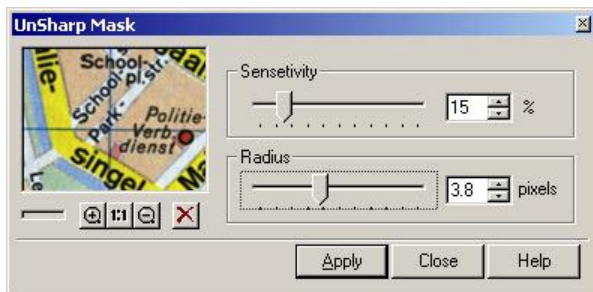

- Set *Radius* – “level” of the filter effect. Increasing the radius value increases the number of pixels surrounding the color boundary that are to be processed.
- Set *Sensitivity* for the filter using the slider or enter the value in the corresponding field. Increasing this value provides a stronger effect.

Applying small *Radius* values results in an increase of sharpness only on color boundaries.

- When you achieve satisfactory results in the Preview window, press the ***Apply*** button.

### ***Median***

This filter reduces image noise, analyzing all pixels within the specified radius and assigning the central pixel the averaged value of reviewed pixels. As a result, pixel color and brightness are evened. For example, Median filter can be used to eliminate image “grain”.

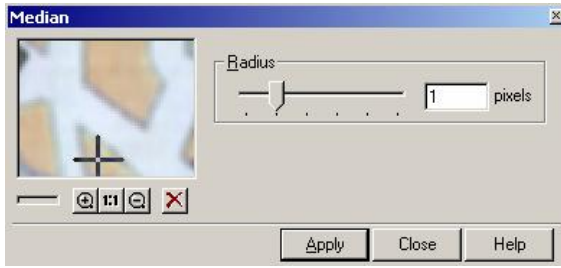

Choose *Median* from the *Filters* menu.

- Set *Radius* for the filter – area within which color values are to be analyzed.
- When you achieve satisfactory results in the Preview window, press the *Apply* button.

## Convert to RGB, Greyscale, 8-bit indexed

### Convert to RGB (greyscale)



- If your document contains several raster images, select the one(s) to convert to RGB (greyscale).
- From the *Image* menu, choose *Convert to*, and then *Convert to RGB (Convert to greyscale)*





### Convert to Indexed colors

You can convert full-color images (24 bit per pixel) and monochrome images to 8-bit-indexed (8 bits per pixel).

This operation can be used to reduce the size of a full-color file, and therefore speed up working with it. Note that in some cases the converted image might have lower quality due to some information loss.

- If your document contains several raster images, select the one(s) to convert to 8-bit indexed.
- From the *Image* menu, choose *Convert to*, and then *Convert to Indexed colors*.

	<i>Execution order</i>
Calculating the optimal palette for the selected image(s)	<ul style="list-style-type: none"> <li>• Press <i>Set auto palette</i> </li> </ul>
Recalculating of palette for specified color number	<ul style="list-style-type: none"> <li>• Specify the color number in the <i>Colors</i> <input type="text" value="256"/> colors field</li> <li>• Press the <i>Reset Palette</i>  button</li> </ul>
Selecting colors from the palette	<ul style="list-style-type: none"> <li>• Press Shift, select colors from the palette by clicking on them (if only selecting one color there is no need to press Shift)</li> <li>• Select the <i>Light Paint</i> checkbox <input checked="" type="checkbox"/> Light Paint button to view selected colors in the Preview window</li> </ul>
Merging selected colors	<ul style="list-style-type: none"> <li>• Press <i>Merge Colors</i>  button</li> </ul>

Deleting selected colors	<ul style="list-style-type: none"> <li>• Press <i>Delete Colors</i>  button</li> </ul>
Changing selected color(s)	<p>Change selected color(s):</p> <ul style="list-style-type: none"> <li>• to the specified color– Press <i>Get color to set</i>  and choose a desired color from the <i>Color</i> box.</li> <li>• to one color of the image – press the button with eyedropper , and then specify a desired color on the screen.</li> </ul>
Adding color(s) to the palette	<ul style="list-style-type: none"> <li>• Enter desired number of colors in the <i>Colors</i> field.</li> </ul> <p>Press <i>Set auto palette</i> </p> <p>– or –</p> <ul style="list-style-type: none"> <li>• Click on a blank palette cell. Click on the added field, and assign the color as described above in section <i>Changing selected color(s)</i>.</li> </ul>

## Separating Color & Greyscale Images to Monochrome Layers

This section describes the operation of separating color or greyscale raster images to monochrome layers.

Binarization allows you to extract pixels of specified colors (or close to them) to a monochrome layer. For example, when you binarize a map, first you get a monochrome layer that contains isolines; then a layer that contains roads, etc.

Color Separation allows you to separate a color or greyscale image to several monochrome layers with a single operation; each image pixel is transferred to one of the resulting monochrome layers.

### ***Binarization***

Using binarization you need to specify the color range(s) for a created layer, e.g., for hydrography layer – from light-blue to dark-blue.



- Choose ***Binarization*** from the *Image* menu.
- Choose binarization method – ***Range*** or ***Threshold***. Set the parameters for the chosen method (Color model (RGB, HSV, Grey), channel (grey, red, green, blue, hue)).
- Specify a layer and its color to place the new monochrome image to.
- Using one of these eyedroppers  specify the colors on the screen; they are added to the list of the *Colors* list. The estimated binarization results are highlighted in the preview window.  
You can choose any incorrectly selected color from the colors list,

and then remove it using the *Delete*  button.

- Tune the results using the sliders located in *Ranges (Threshold)*.
- You can delete small speckles that appear using the slider *Noise Reduction*.
- When you achieve satisfactory results in the Preview window, press *Apply*.

### ***Color separation***

To execute Color separation set color categories (thematic layers), by which you want to separate the image, and then set a list of colors for each category.

- Choose *Color separation* from the *Image* menu.
- Specify the first category color on the image using the eyedropper *Add category* . Choose a standard color; specify a name for the category in the displayed *Category name and color* dialog.
- Using the eyedropper *Add color*, specify all colors of the image, which should fall within this category.
- Repeat the previous two steps for all categories, which you want to set on a new layer. Incorrectly defined categories and colors can be selected and deleted from the list using the *Delete*  button.
- Using the *Noise Reduction* slider you can adjust the sensitivity of *Color separation* – smooth contours.
- Deleting small-sized speckles is executed when the *Despeckling* checkbox is set to on.
- When you achieve satisfactory results in the Preview window, press *Apply*.

## **Advanced Color Tools**





### ***Color Classifier***

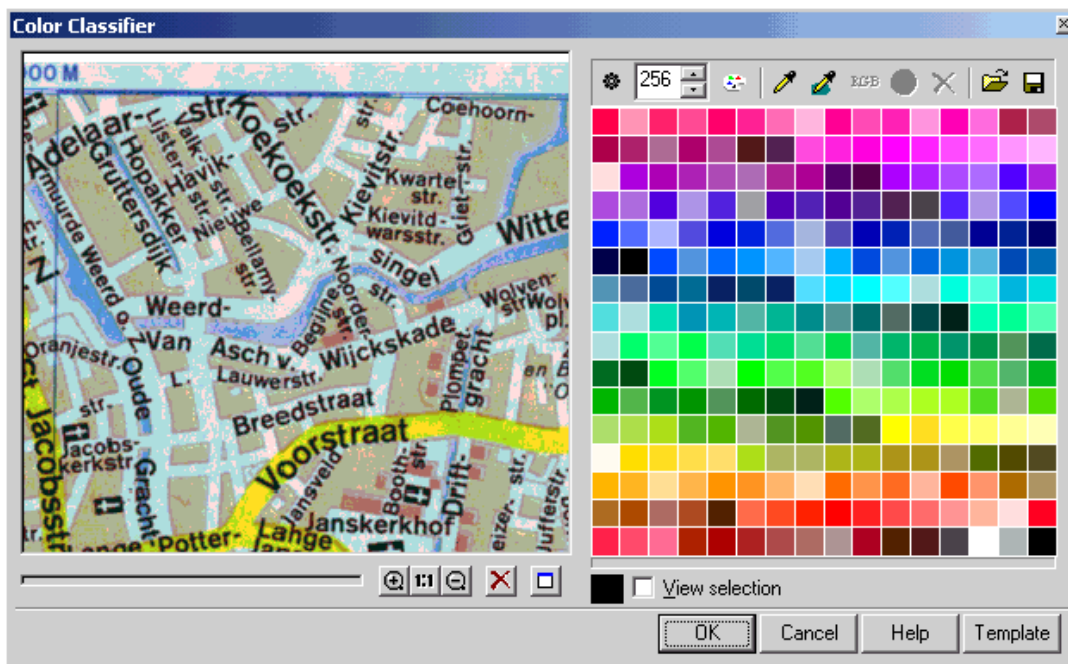





This versatile tool allows you to manage the colors within the image. It is not applicable to monochrome images. You can reduce the palette by deleting the selected color or colors or by merging several colors into one. You can also replace selected colors and add them to the palette.

To open *Color Classifier* dialog - choose *Color Classifier* from the *Image* menu.



The buttons and controls in the Color Classifier dialog window

	Color samples table	This table contains color samples of the current palette. Select a color by clicking on it. Clicking while holding down SHIFT selects multiple colors.
	Color counter	This control is used to show the number of colors in the current palette (from 2 to 256). You can increase or reduce this number.
	Set auto palette button	By pressing this button WiselImage will automatically determines the set of colors that most truly represents the image and places them into the color samples table.
	<i>Recalculate palette</i> button	By pressing this button you force WiselImage to reset the palette up to the number specified in the counter
<input checked="" type="checkbox"/> View selection	View Selection	When this box is checked, the points of selected colors are shown on the image.
	<i>Choose a color from the image</i>	This tool is used to obtain a color by clicking on a pixel in the document window. The color of the selected pixel will be highlighted in the Color samples table.

	<i>Select colors from the image</i>	This tool is used to obtain colors by drawing a polygon around an area in the document window. Double-click to finish the polygon. The colors contained within the polygon will be selected in the Color samples table.
	<i>RGB button</i>	Opens the color selection dialog, which lets you replace the currently selected color with a new one.
	<i>Merger button</i>	Merges the colors selected in the color samples table to the mean color.
	<i>Delete button</i>	Deletes the colors selected in the color samples table from the palette.
	<i>Save LUT</i>	Saves the current palette in a Look-Up Table (LUT) file.
	<i>Load LUT</i>	Loads the current palette from a Look-Up Table (LUT) file.
	<i>Template</i>	You can save and load color palette information to and from a template file using this button.

When the palette will be build – press **OK**.

### ***Adaptive Binarization***

Adaptive Binarization tool eases the conversion of scanned Grayscale images with difficult background. This brand new tool makes a workflow while operating with a drawings and sketches on a rough colored background (i.e. blueprints and sepias) fast and easy.

Choose ***Adaptive Binarization*** from the ***Image*** menu.

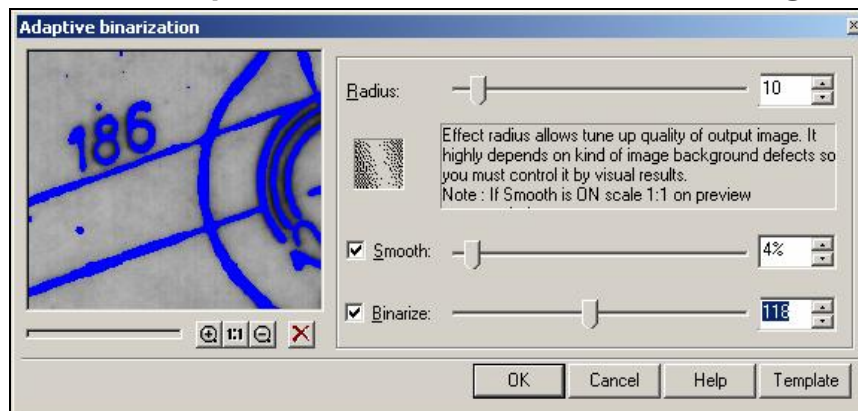

- Set *Radius* – “level” of the filter effect. Increasing the radius value increases the number of pixels surrounding the color boundary that are to be processed. Generally, the best results can be attained by setting the *Radius* value approximately two times thicker than the thickest linear object on the image.
- Set *Smooth* checkbox (if required) and adjust the parameter. Using smoothing with the *Binarize* checkbox set to off produces a cleaner image with the background evened and line objects revealed
- Set *Binarize* checkbox (if required) and adjust the parameter. *Binarize* – binarization using *Threshold* value. The method used – Threshold by grey – is described in the previous section.

## Rasterizing; Merging Raster Images

### Rasterizing Vector Data

You can rasterize vector data on raster images, and either retain or delete the original vector objects.

Select the vector objects to rasterise; must be located over the raster image.

Choose *Merge (Rasterize)* from the *Modify* menu.

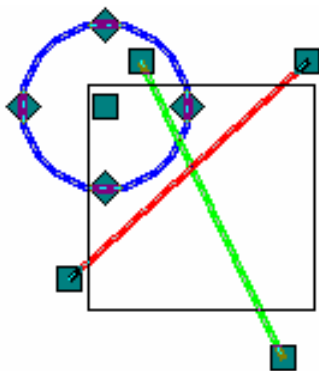

*Original vectors*

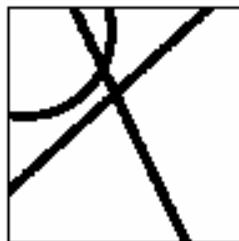

*Rasterizing on monochrome raster*

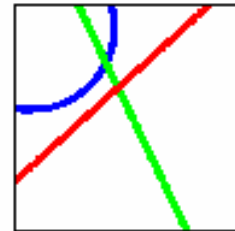

*Rasterizing on color raster*

Vector objects located outside the boundary of the raster image disappear.

If vector objects are located over several raster images, they are rasterized on all visible images, located on unlocked layers.

If you want to rasterize vector objects without removing the vector originals, use the command *Merge a copy (Rasterize)* from the *Modify* menu.

### Merging Raster Images

You can merge a raster image or raster selection with another raster image.

Select a raster image (or its fragment) and choose *Merge*

**(Rasterize)** from the **Modify** menu.

If the selected raster data (or part of it) is placed outside the destination raster image area, it disappears.

If the selected raster data is located over several raster images, it is rasterized on all visible images, located on unlocked layers.

If you want to merge a raster image without removing the original image, choose **Merge a copy (Rasterize)** from the **Modify** menu.

## Tracing

Tracing is an interactive (or semi-automatic) vectorization procedure.

During the tracing procedure raster objects are specified one by one, these are then recognized by the program and converted to corresponding vector objects.

In the process of tracing the original raster objects can be deleted, smoothed or left intact.

### Tuning Tracing

You should tune the tracing parameters before applying this procedure.

Tracing is tuned in the **R2V Conversion Options** dialog or by the **Raster Properties** toolbar (for quick preview).

#### Raster Properties toolbar quick preview

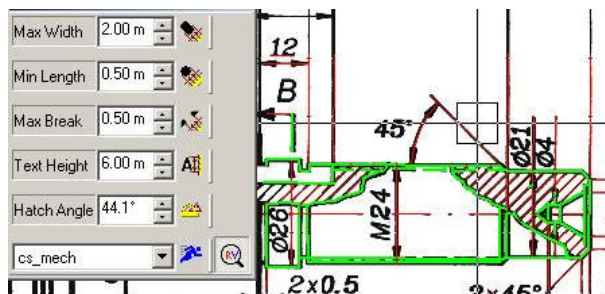

- Tune the parameters in the same manner as will be described below
- Select **Draw R2V preview**  
 button
- Draw by rectangle the preview zone of the image.

To specify all the conversion setting for tracing - choose **Conversion Options** from the **Convert** menu.

#### **Tuning geometry of traced objects:**

Open the **Options** tab of the **R2V Conversion Options** dialog.

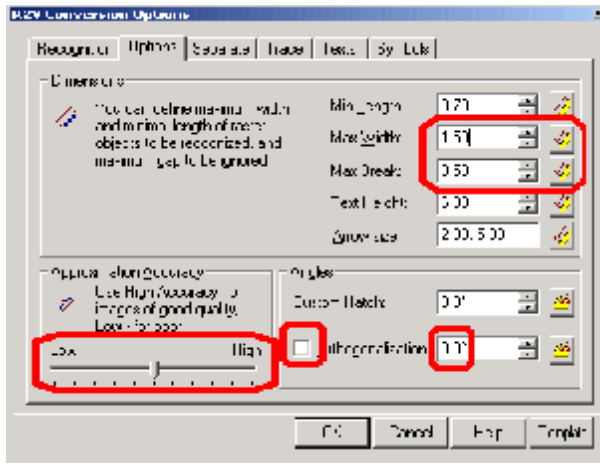

**Max.Width** – maximum width of traced raster objects. Measure width of the widest traced lines. Set this parameter value slightly greater than the measured width.

**Max. Break** – length of ignored break of raster lines.

If you trace dashed lines, set the value of this parameter slightly greater than the maximum gap between dashes.

**Accuracy** – set the accuracy value for tracing polylines to high (for more precise approximation of raster curves with vector polylines). In other cases increase the accuracy value for images of good quality; and reduce the value for images of poor quality.

### Layering resulting vector objects

You can place resulting vector objects on different layers:

- Create the desired layers in Layer Manager.

See section *Layer Manager* on page 8 for information on *Layer Manager*.

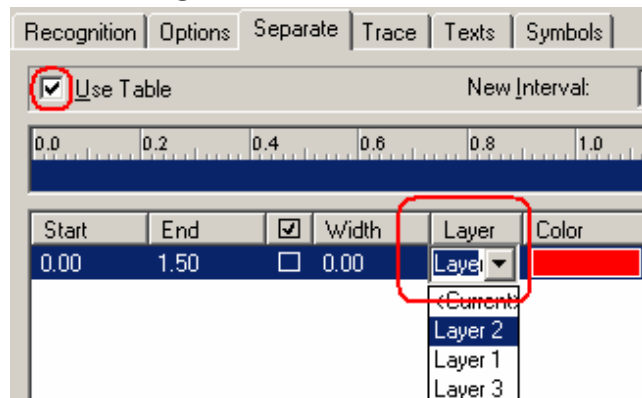

- Open the **Separate** tab of the **R2V Conversion Options** dialog.
- From the pull-down list of **Layer** select one to place the traced vector object.
- Select the **Use Table** checkbox.

### Orthogonalization mode with tracing

When tracing lines and polylines, you can use **orthogonalization mode**, which allows you to obtain orthogonal vector lines and polylines that consist of orthogonal segments (the base angle can be calculated automatically or specified).

- **Tracing lines with orthogonalization**  
**IMPORTANT:** The operation can only work if the raster line you want to trace deviates from the orthogonal (or specified) direction by no more than  $2^0$ . *To turn on line orthogonalization mode:*

Open the **Options** tab of the **R2V Conversion Options**

- dialog.  
 Select the **Orthogonalization** checkbox.
- If necessary enter the base angle value in the **Base Angle**

field, and then clear the *Auto Estimate base angle* checkbox.

- **Tracing with resulting polyline of orthogonal segments**

*This information is provided in section Tracing polylines with orthogonal segments on page 58*

## Tracing Modes and Commands

*Before executing tracing, you should choose a tracing mode.*

*Tracing modes:*

	Original fragment	
	Produce vector and keep raster	
	Produce vector and erase raster	
	Erase raster without producing vector	
	Smooth raster without producing vector	

*Tracing command:*

You can trace:

	Lines, arcs, circles with auto recognition		Hatches which consists of lines
	Lines by two points		Raster symbols
	Arcs by three points		Polylines
	Circles by two points		Outlines

## How to Trace

- Set the tracing parameters

*Information on setting tracing parameters is provided on page 53.*

- Choose from the *Raster to vector* toolbar or from the *Trace* menu:
  - Tracing mode
  - Tracing command

Information on tracing modes and commands is provided on page 55.

## Tracing Lines, Arcs, Circles, Outlines



You can trace raster lines, arcs, circles, and outlines with automatic recognition of their type – click once on the desired object.



If you work with a complicated image, or an image of poor quality, or you need to vectorize only part of a raster entity, you can apply forced tracing.

**Auto extension mode:** When tracing lines or arcs you can use the **Auto extension mode** – you only need to specify a fragment of the object, but the program recognizes the whole object. To switch to this mode select the *Auto extend vectors* checkbox in the *Trace* tab of the *R2V Conversion Options* dialog.

## Tracing Hatches

To trace a hatch, you need to intersect all its lines with a crossing polyline.

raster lines that cross the hatch interfere in the recognition operation, so before tracing the hatch, it may be useful to trace these lines and erase the original raster.

<p><i>Original hatch</i></p>	<p><i>Tracing lines that intersect hatch (with erasing the original raster)</i></p>	<p><i>Tracing hatch – intersecting hatch lines</i></p>	<p><i>Result of hatch tracing (in Produce Vector and Erase Raster mode)</i></p>

## Tracing Polylines

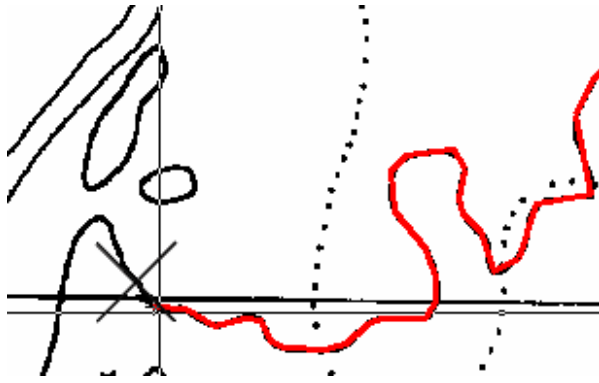

Tracing polylines produces vector polylines which approximate raster curves.

To increase accuracy of approximating vector polyline to the original raster curve increase the *Accuracy* slider in the *Options* tab of the *R2V Conversion Options* dialog.

---

See page 54 for information on tuning tracing.

### How to trace polylines

- Select tracing mode (e.g., Produce Vector and Keep Raster).

---

*You can see the information of section Tracing Modes and Commands on page 55.*

- Run the Linefollowing command.
- Specify a point on the raster curve – the program tracks this curve up to the nearest intersection and waits for you to indicate the direction in which tracing should continue. You can also use the *Autodetect direction* mode: Open the *Trace* tab of the *R2VConversion Options* dialog. Select the *Autodetect direction* checkbox. Set the waiting period (in sec) in the *Pause* field.
- If you turn on the *Autodetect direction* mode, and you are satisfied with the autodetected direction, indicated by a cross, press the *Space* key (alternatively, the program continues tracing after the waiting period expires). If you are not satisfied with the direction suggested by the program, specify the right direction on the screen. If *Autodetect direction* mode is off, you must specify the next fragment of the raster curve on screen (fragment between two nodes or between node and end point of the raster curve).
- If you need to change the tracing direction, chose *Change direction* from the context menu.
- To cancel the last segment of the vector polyline, press *Ctrl+Backspace*.
- To cancel the last step, press *Backspace*.
- If needed, you can draw segments in *Free Hand Drawing mode*. Press Shift and specify the new nodes of the vector polyline on the screen.
- When you have completed tracing the polyline, press *Enter*.

You can use the *Centralize View* command from the context menu for convenience.

### Tracing polylines with orthogonal segments

When tracing, you can obtain vector polylines with orthogonal segments. For example, this mode can be used to trace buildings on scanned maps.

The direction of the first segment can be estimated automatically or specified.



To obtain polylines with orthogonal segments:

- Open the Trace tab of the *R2VConversion options* dialog. Select the *Line Follow Orthogonalization* checkbox.
- Select the *Autoestimate Base Angle* checkbox or specify the angle for orthogonalization in the *Base Angle* field or by the measure button.



You can reduce the *Accuracy* value to avoid creating unnecessary segments.



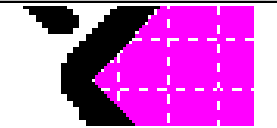
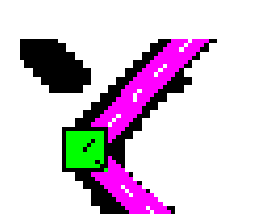

See page 54 for information on tuning tracing.

If needed, you can create a vertex at each point of intersection on the polyline. – Select the *Place vertex on nodes* checkbox in the *Trace* tab of the *R2VConversion options* dialog

### Tracing Outlines

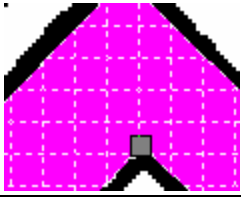
You can trace raster outlines. Tracing results depend on the parameters and mode of tracing. Tracing parameters are set in the *Trace* tab of the *R2V Conversion Options* dialog.

Setting parameters of tracing outline		
Auto Extend vectors – Off	Creates vector on two colors boundary.	
Auto Extend vectors – On	Creates vector at the center of raster line. Raster line width is specified with the Options tab of the <i>R2V Conversion Options</i> dialog.	
Export single contour – Off	Creates outer and nested outlines.	

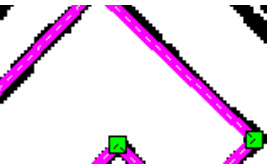
<p>Export single contour – On</p>	<p>Creates the outer outline only.</p>	
<p>Auto Extend vectors – On Export single contour – On</p>  <p>Trace mode – keep raster</p>	<p>Raster data inside the outline is kept.</p>	
<p>Auto Extend vectors – On Export single contour – On</p>  <p>Trace mode – erase raster.</p>	<p>Raster data inside the outline is erased.</p>	

### How to trace outlines

- Set the trace outline parameters.
- Specify the tracing mode (for example, Produce Vector and Erase Raster).

---

*You can see information of section Tracing Modes and Commands on page 55*

- Run the Trace Outline command.
- Specify a point inside the outline.

### Tracing Raster Symbols

---

*See section Polylines collecting*

*The Collect Polylines command is designed for assembling vector polylines obtained as a result of the trace or automatic vectorization. When checking the results it is best to use the raster image as a substrate.*

To perform polylines collecting do following:

- Choose the *Collect Polylines* from the *Correct* menu to start this command.
- Click the first polyline.
- While the cursor is moving, you can see which polyline will be added to the current one and what you will have as a result. Choose the next polyline by clicking on it. Click the next polyline. The program automatically pans to the end point of the resulting object.

Use right-button menu during command running:

<i>Back step</i>	Cancels the latest step.
<i>Cancel</i>	Cancels the command and current polyline creation.
<i>Continue</i>	Continues the command.
<i>End</i>	Finishes current polyline collecting.
<i>Close</i>	Closes current polyline.
<i>Change Direction</i>	Changes the current collecting direction.
<i>Centralize View</i>	Pans an image to show the latest added polyline nodes at the screen center.

- Set **Auto Properties** item in Inspector to off value and change the properties of the resulting polyline (such as its color, thickness, markers) in during the command execution.
- Use special modes for modifying the resulting object during polyline assembling process:

Case 1: polyline1 has a stray tail, and you need to attach it to polyline2

Press CTRL and click a point on the current polyline1 in which it must be broken. You will continue polyline assembling from this point.



**Case 2: polyline2, which you want to append, has a stray head**

Press **CTRL** and specify a point on polyline2 to which it must be attached. It will be broken in this point and added to polyline1.



**Case 3: to close a current polyline**

Press **CTRL** and click on one of the current polyline end points.

The polyline will close and the command will be finished. The closed polylines are highlighted with rounds, instead of a square form for grips.

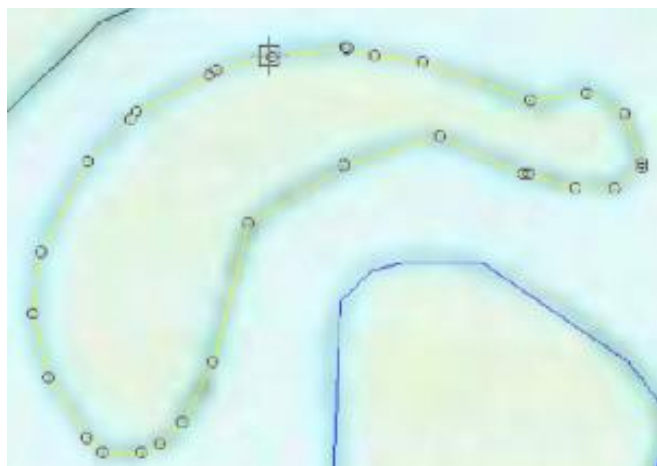

**Case 4: to draw a segment of a polyline manually**

Press **SHIFT** and draw as many segments as necessary.



Case 5: to add some vertices to a current polyline  
Press CTRL+SHIFT and add a necessary number of vertices.

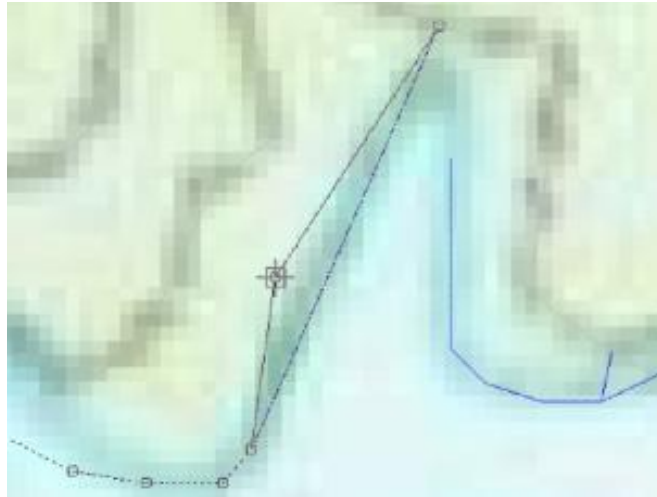

---

*Working with Raster Symbols on page 71 for information on tracing raster symbols.*

## Automatic Vectorization, Text Recognition

Automatic vectorization is a procedure for converting raster data to appropriate vector objects.

WisImage recognizes the following objects when vectorizing: lines, arcs, circles, hatches, points, texts and symbols. Raster curves and filled contours are approximated with vector polylines.

The program can recognize line styles and arrows on line and arc ends.

You can train the program to recognize new symbols and texts.

You can round vector object widths to specified values. You can also place vector objects corresponding to raster lines of various widths on different layers and/or assign different colors to them.

## Tuning Vectorization

You can use one of the pre-defined templates or tune the parameters yourself.

Vectorization parameters can be saved as a template for further use.

Automatic vectorization is tuned in the *R2VConversion Options* dialog or by *Raster Properties* (for quick preview) – see Tracing. To open the dialog, choose *Conversion Options* from the *rConvert* menu.

**Select objects to recognize:**

Open the *Recognition* tab of the *R2VConversion Options* dialog.

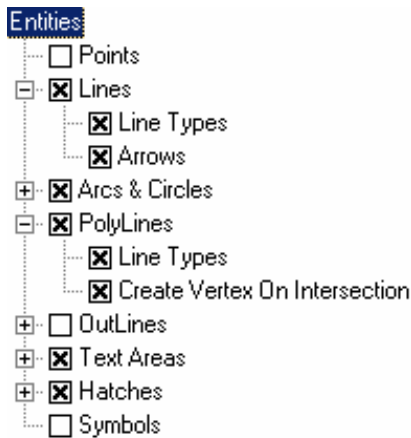

Select the entities, which you want to obtain after vectorization – select the corresponding checkboxes.

The additional parameters for recognized objects, such as line type, arrows, hatch angle, and others are located on the second level. Click on “+” to get access to these parameters.

### Setting the geometry of vectorized drawing:

The geometry is set in the *Options* tab of the *R2Vconversion Options* dialog.

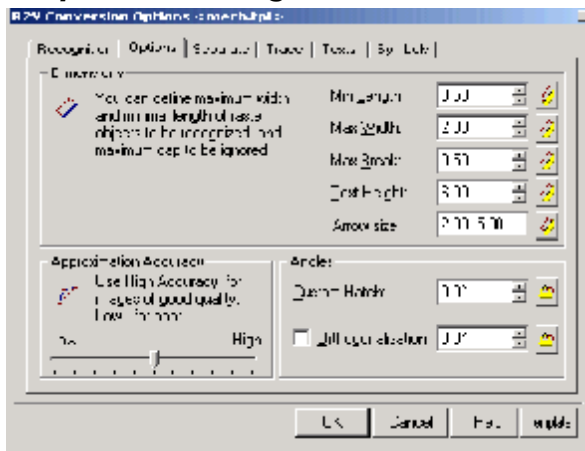

**Min Length** – minimum length of a raster object to be recognized. (For example, enter 1 mm in the *Min Length* field so that raster fragments smaller than 1 mm will not be recognized).

**Max Width** – maximum width of raster lines. Set the value of this parameter slightly greater than the measured line width on your drawing.

**Max Break** – maximum accepted length of a break in a raster line to be ignored. Set the value of this parameter slightly greater than the distance between dashes in dash lines or the broken distance in poor quality lines.

**Text Height** – Set the value for this parameter equal to the maximum height of raster text symbols of upper case.

**Accuracy** – this parameter corresponds to the accuracy of your raster image. Use a high Accuracy value for images of good quality, and a low Accuracy value– for images of poor quality.

**Orthogonalization** – select this checkbox to obtain orthogonal vector lines as a result of vectorizing raster lines, which deviate from the orthogonal direction by not more than  $2^0$ .

You can also align vector objects to a specified base angle; enter the angle value in the corresponding field.

### Separating vector objects by layer and /or by color

The criteria for separating vector objects (by layer and/or color) is the width of the original raster lines.

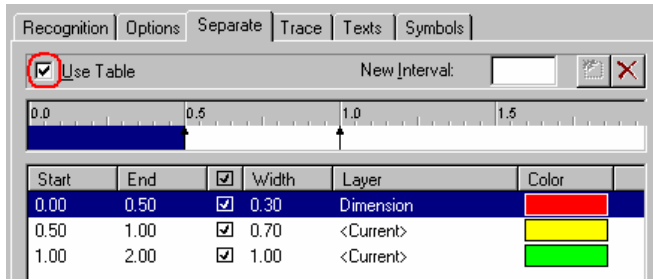

In the *Separate* tab of the *R2V Conversion Options* dialog, you can:

- Specify width of resulting vector objects
- Separate resulting vector objects by color
- Separate resulting vector objects by layer

In the *Width* field you can specify widths for vector objects obtained after vectorization of raster objects with line widths included in the interval, defined with the *Start* and *End* fields. You can also define a layer and/or color for these vector objects in the corresponding fields.

## How to Vectorize

- Set vectorization parameters.

*Information on tuning vectorization is provided on page 62*

- If you have several images in your document, select the one(s) to vectorize.  
You can also vectorize a selected image fragment or image clip.
- Choose *Raster2Vector* from the *Conversion* menu.

## Text Recognition

This section provides information on various algorithms for recognizing raster text; the procedure and parameters of setting up raster text recognition.

### Text Recognition Algorithms

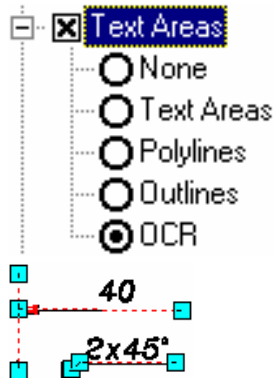

You can use the following algorithms for working with raster texts. You can choose them using the *Recognition* tab of the *R2V Conversion Options* dialog.

*None* – this algorithm searches for raster text areas without vectorizing.

*Text Areas* – this algorithm recognizes and creates text areas. You can enter text information in these text areas using the procedure of editing recognized texts.

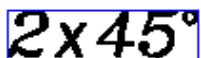

*Information on editing recognized texts is provided below on the current page*



*Polylines (Outlines)* – approximating the raster text with vector polylines (outline).



**OCR** – recognizing the raster text and creating the corresponding text objects.

### How to recognize text

- Select the **Text Area** checkbox in the **Recognition** tab of the **R2V Conversion Options** dialog.
- Choose your required algorithm for working with the raster text.
- In the **Options** tab of the **R2V Conversion Options** dialog set the **Text Height** value equal to the maximum height of raster text symbols of upper case.
- Tune the text recognition options in the **Texts** tab of the **R2V Conversion Option** dialog.

See section **Text recognition options** on page 65 for information on tuning text recognition options.

- **Editing recognized texts**  
The procedure of editing recognized texts (text areas) is used after recognition with the OCR module or with Text Areas recognition.

After applying automatic vectorization choose the command **Edit OCR Texts** from the **Convert** menu. The program displays the first recognized text fragment (area), the content of which appears in the **Text Correction** dialog.

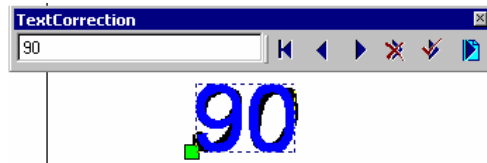

You can edit the text area contents. To accept the text and move on to the next one press the **Accept Recognized Text** button of the **Text Correction** dialog. To delete the current text, press **Delete OCR Text** button in the **Text Correction** dialog.

### Text recognition options

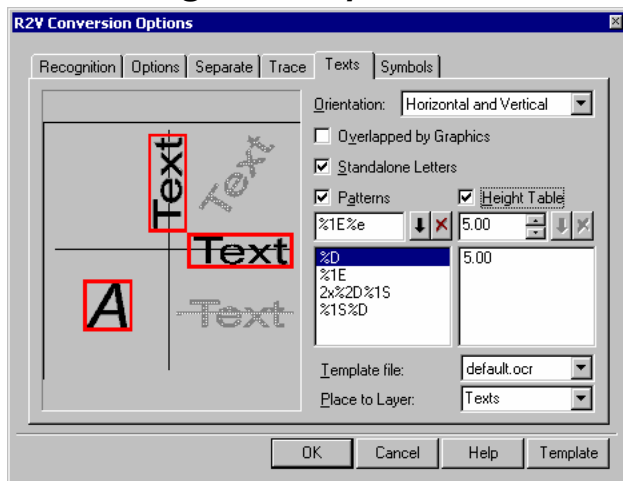

**Orientation** – choose the orientation for raster texts contained in the image.

**Overlapped by Graphics** – if this option is on, the program searches for raster texts, crossed with other raster objects.

It is not recommended to use this mode when working with complicated documents to avoid possible mistakes, such as incorrect recognition of small graphic objects as texts.

**Only Standalone Letters** – allows searching for standalone text characters.

If this option is off, the program does not search for

standalone text characters, but you can avoid incorrect recognition of small objects.

**Patterns** – If you use the OCR module, you should set patterns for text inscriptions contained in the raster document to obtain better recognition results. Select the *Word pattern* checkbox.

If *Patterns* are not specified, the program uses a set of standard patterns.

**Height Table** – if after vectorizing, you want to obtain texts of specific height, enter the desired text height(s) in the table and select the **Height Table** checkbox. If you specify several height values, texts height will be rounded to the nearest value from the list.

**Template file** –file for storing topology models of text characters, which are used when performing OCR.

You can also train the program to recognize other text characters or different forms of characters contained in the standard template file.

---

*Information on training OCR is provided on page 67.*

### **Setting text pattern**

Text patterns can comprise of fixed and variable parts.

Here is formal description of word pattern definition:

**length** – number of letters (you do not need to specify this, if length will be different),

**character type** – type of letter sequence

Types of letters are presented in the following table:

D	Digits
N	Capital letters of national alphabet
n	Small letters of national alphabet
E	Capital letters of Latin alphabet
e	Small letters of Latin alphabet
S	Special characters (signs of plus, minus, equality, degree, and others)

For example, 5V, 220V, 13.8V: 5,220,13.8 – variable part, V – fixed. Therefore, the pattern can be defined as %DV. The length is different, so it is not specified).

**Examples:**

Symbol sequence	Pattern
5 25 5559 22.9	%D
R25 R15 R13	R%2D
Moscow Hanover	%1E%e
project design	%n

5V	220V	13.8V	%DV
12 <sup>0</sup>	30 <sup>0</sup>	45 <sup>0</sup>	%2D%1S

## Training OCR

You can train the OCR module to recognize new characters. You can add a new character to one of the standard template libraries or create your own.

In some cases it is more convenient to use the standard library (e.g., DEFAULT.OCR) as basis, having saved it with a new name.

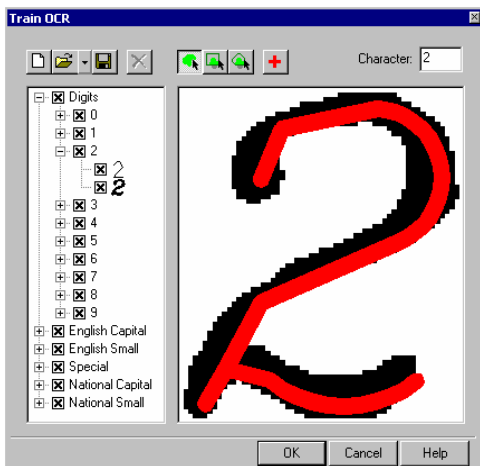

To train the program to recognize a new character or different forms of existing characters:

- Choose *Train OCR* from the *Conversion* menu.
- Open (create) OCR-file.
- Enter a character to recognize in the *Character* field.
- Select the corresponding character on the raster image using one of the selection buttons.

- Press "+" to add the new pattern to the OCR-file.
- Save the OCR-file.

## Automatic Raster to Contours vectorization

Performs a *Raster to Contours* conversion by polylines which duplicates selected closed areas on the image. At the same time, if an area has a mutual border (example shown below), every area (parcel) of polylines will have its own segment.

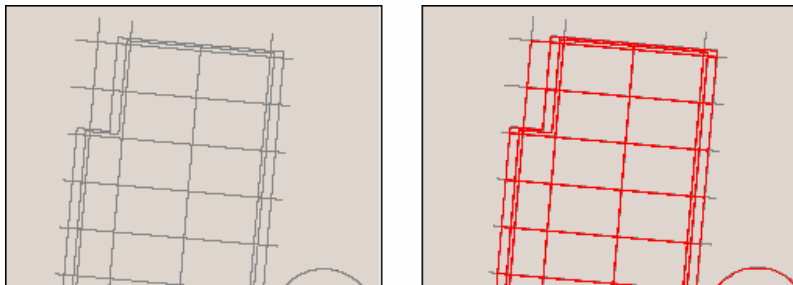

Setting up the Raster to Contours parameters can be performed in *R2V Conversion Options*.

Increasing the *Radius* parameter causes more places to be treated as area borders

To perform conversion to contours do following:

- Open the monochrome raster image.
- Choose *Raster to Contours* from the *Convert* menu or click the



button on the *Raster to Vector* toolbar.

- If you are not happy with Raster to Contours conversion try

changing the parameters in *Conversion Options* and re-run the command.

## Automatic Color vectorization

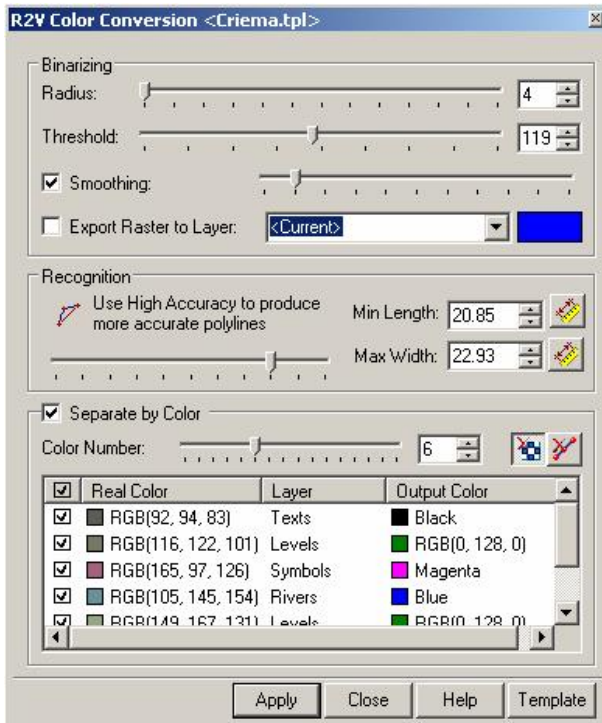



The *Color Conversion* intended for recognition of the linear objects on the color schematic raster images (plans, schemes, topographical maps). It combines such operations as binarization, vector color separation and color vectorization. As a result, you get polylines broken in places of mutual crossings.

This command works on grayscale and color images.

To start *Color Conversion* command choose *Color Conversion Options* from the *Convert* menu or click the  button on the *Raster to Vector* toolbar.

*To tune the color conversion parameters do following steps:*

### Step1:

- Adjust the binarization parameters (similarly to *Adaptive Binarization*):
- Switch on the *Export Raster to Layer* checkbox.
- Switch off the *Show Vectors* button  of this dialog and switch on the *Show Raster* button .
- Move the *Radius* slider to its minimum position (equal to 4).
- Gradually increase the *Threshold* value until the required objects appear.
- Use the *Smoothing* filter if the objects have rough borders.

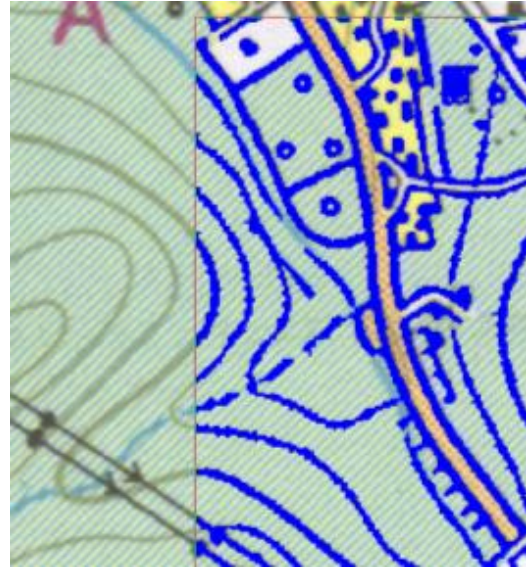

---

*At the same time, closely positioned lines might conglutinate and small objects might disappear.*

Turn off the *Export Raster to Layer* checkbox after adjusting the binarization settings. If you think this monochrome raster is necessary, you can switch this checkbox on after all the other settings adjustment are complete

### Step2:

Set the Recognition parameters: *Max Width*, *Min Length* and *Accuracy*.

Those parameters are equal to those for monochrome images in the raster to vector *Conversion Options* dialog and the *Raster Properties* toolbar.

### Step3

- Switch off the **Separate by Color** checkbox and define a preview area so that you can see all the objects of all the colors resented in the raster image.
- Visually check up the quality of the recognized objects, their color and a degree of conformity to the raster image. Recustomize parameters if necessary.
- If you want to see lines of different colors on separate layers, switch on the **Separate by Color** checkbox.
- After defining the correct number of colors you can define another target color and a layer for each real color.
- If you do not want to export a line of a certain color, switch off the **Export** checkbox at the beginning of this string.

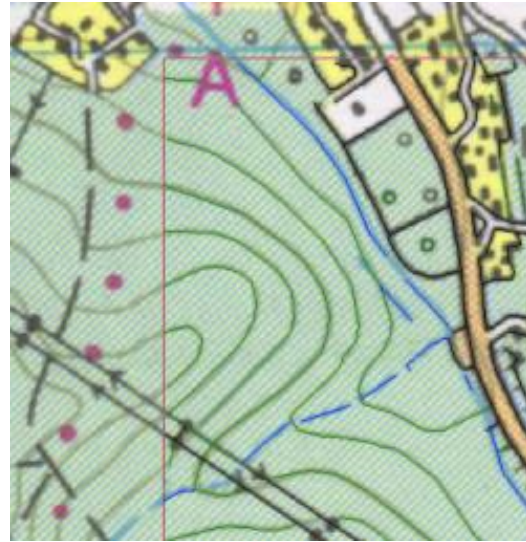

### Step4:

Click the **Apply** button to start vectorization or save the parameters to a file for further use.

---

*You can also launch vectorization with current settings through the Raster2Vector command (chose the Raster2Vector from*



*Convert menu or click the button on the Raster to Vector toolbar).*

## Correcting Vectorization Results

Vectorization results usually need further editing and correcting. The program has both an automatic and interactive correction procedure intended for this purpose. It has also polylines correction command.

### *Automatic correction of vectorization results*

This operation restores contact of arcs and circles, “merges” vector fragments; removes vector “speckles”, aligns lines to regular directions (angle  $0^{\circ}$ ,  $30^{\circ}$ ,  $45^{\circ}$ ,  $60^{\circ}$ ,  $90^{\circ}$ , etc.), if their deviations do not exceed the angle specified by user.











### *How to correct vectorization results automatically*

- Choose **Vector Correction Options** from the **Conversion** menu or press the  button on the **Vector Correction** toolbar.

- Using the displayed *Vector Correction Options* dialog, specify the autocorrection operations and parameters. Close the dialog by pressing OK.
- Select vector objects to apply autocorrection.
- Choose *Vector Autocorrect* from the *Conversion* menu or press the  button on the *Vector Correction* toolbar.

### *Interactive correction of vectorization results*

After applying automatic correction, it is recommended that you also use the manual correction (interactive). The commands for interactive correction are located on the *Vector Correction* toolbar. Using interactive correction you can:

<i>Commands for interactive vector correction</i>	
	Join selected vector fragments to a polyline
	Join selected vector fragments to a circle
	Join selected vector objects to an arc
	Join selected vector objects to a line
	Join selected vector objects to create the closest matching (in terms of geometry) single vector object
	Trim vector objects
	Expand vector objects
	Break at specified point
	Correct to intersection
	Align Angle and Distance

*See more detailed information on editing vector objects on page 30.*

### *Polylines collecting*

The *Collect Polylines* command is designed for assembling vector polylines obtained as a result of the trace or automatic vectorization. When checking the results it is best to use the raster image as a substrate.

To perform polylines collecting do following:

- Choose the *Collect Polylines* from the *Correct* menu to start this command.

- Click the first polyline.
- While the cursor is moving, you can see which polyline will be added to the current one and what you will have as a result. Choose the next polyline by clicking on it. Click the next polyline. The program automatically pans to the end point of the resulting object.

Use right-button menu during command running:

<i>Back step</i>	Cancels the latest step.
<i>Cancel</i>	Cancels the command and current polyline creation.
<i>Continue</i>	Continues the command.
<i>End</i>	Finishes current polyline collecting.
<i>Close</i>	Closes current polyline.
<i>Change Direction</i>	Changes the current collecting direction.
<i>Centralize View</i>	Pans an image to show the latest added polyline nodes at the screen center.

- Set **Auto Properties** item in **Inspector** to off value and change the properties of the resulting polyline (such as its color, thickness, markers) in during the command execution.
- Use special modes for modifying the resulting object during polyline assembling process:

**Case 1: polyline1 has a stray tail, and you need to attach it to polyline2**

Press **CTRL** and click a point on the current polyline1 in which it must be broken. You will continue polyline assembling from this point.



**Case 2: polyline2, which you want to append, has a stray head**

Press **CTRL** and specify a point on polyline2 to which it must be attached. It will be broken in this point and added to polyline1.



**Case 3: to close a current polyline**

Press **CTRL** and click on one of the current polyline

end points. The polyline will close and the command will be finished. The closed polylines are highlighted with rounds, instead of a square form for grips.

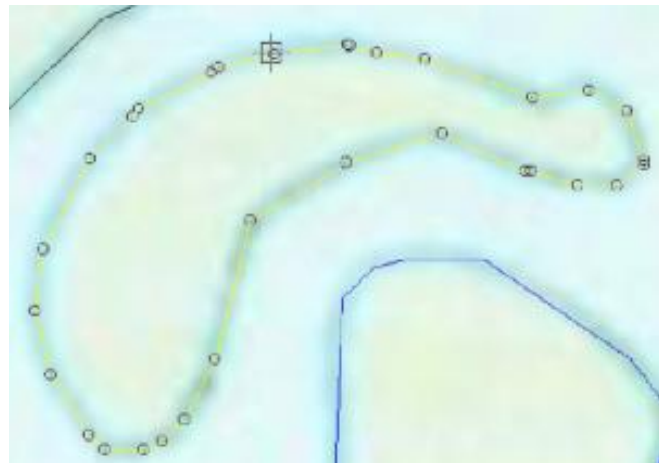

**Case 4: to draw a segment of a polyline manually**

Press **SHIFT** and draw as many segments as necessary.



**Case 5: to add some vertices to a current polyline**  
 Press **CTRL+SHIFT** and add a necessary number of vertices.

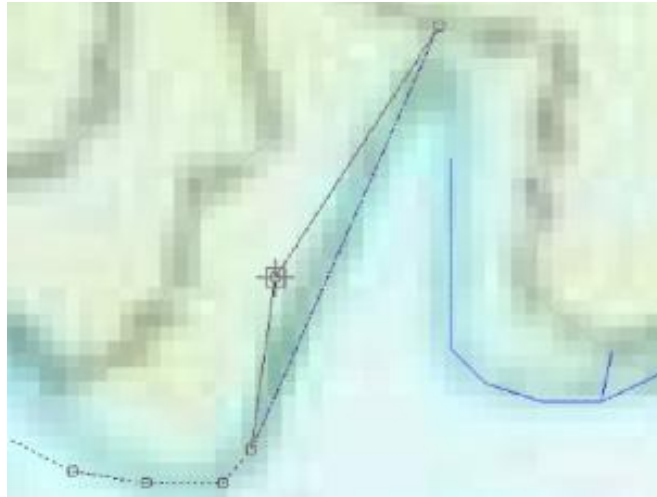

## Working with Raster Symbols

The new algorithm of WiselImage allows you to recognize, select and vectorize not only raster entities such as lines, arcs, circles, and others, but also raster symbols. For example, units of electric and technology schemes, labels of windows, staircases, sanitary equipment on premises plans, and more.

Raster symbols are recognized in accordance with patterns stored in special template libraries. A raster symbol can be rotated and have a different scale. You can train the program to recognize new symbols. Before selecting, tracing, and vectorizing a raster symbol, you need to include the corresponding template in the *Symbols* tab of the *R2V Conversion Options* dialog box.

### Training to Recognize Symbols

1. To recognize a raster symbol you need to create the corresponding vector template. This can be performed using vectorization, tracing, or simply by drawing vector objects over the raster symbol.

**INFORMATION:** You can group vector objects to a block and use this block as a template.

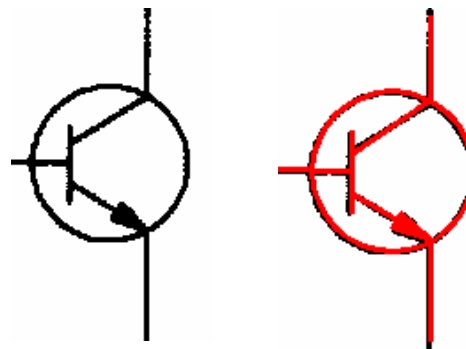

*Raster symbol*

*Vector template*

## 2. Save the template in a special library.

- Select the vector template.

*Information on vector selection is provided on page 26*

- Choose **Train Symbol** from the **Convert** menu.
- If the symbol has connection lines specify them with the **Select connection lines**  button of the **Train Symbols** dialog.

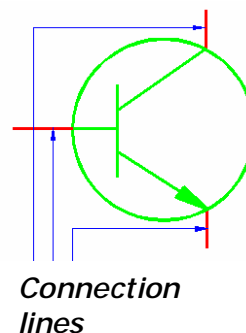

**Connection line** – line of variable length, with which a symbol is connected to other objects. Set a corresponding name for further convenient use.

- Save the symbol using the **Save As** button of the **Train Symbols** dialog.

**INFORMATION:** The location of the root folder for storing templates is defined with the **Preferences** dialog. As each template is stored in a separate file, it is wise to group symbols files into sets of subfolders.

## Tuning Symbol Recognition Options

The parameters of selecting, tracing and automatic vectorizing of raster symbols are set in the **Recognition** and **Symbols** tabs of the **R2V Conversion Options** dialog.

Choose **Conversion Options** from the **Convert** menu.

- Open the **Recognition** tab and select the **Symbols** checkbox.
- Open the **Symbols** tab.

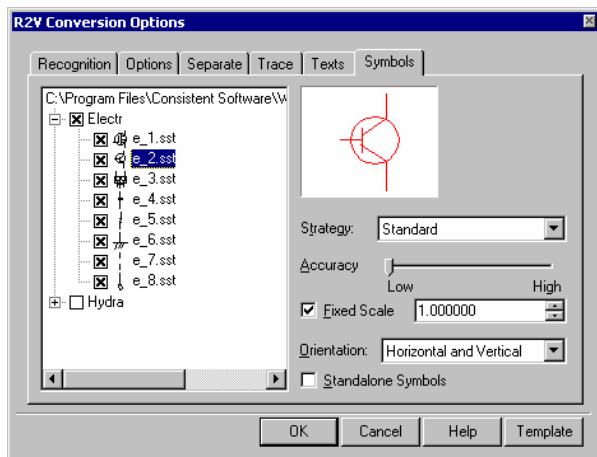
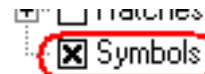

Select the checkboxes of the required categories (includes all symbols of category) or standalone symbols

**Strategy** – this parameter influences the speed and quality of symbol recognition. Set **Standard** or **Smart**.

**Accuracy** – this parameter defines acceptable deviation of the raster symbol from the template. Use a higher accuracy value for raster images of good quality, lower – for images of poor quality.

**Fixed Scale** –if the **Fixed Scale** checkbox is on, only those raster symbols, which size coincide with the size of corresponding templates or different from them by specified scale factor are recognized. If the **Fixed Scale** checkbox is off, raster symbols of different scale

will be recognized.

**Orientation** – specifies the raster symbol orientation relative to the templates' orientation (choose *Horizontal*, *Horizontal and Vertical* or *Arbitrarily oriented*).

**Standalone Symbols** – select this checkbox, if you have only standalone symbols on your image.

## Selecting, Tracing, and Vectorizing Raster Symbols

1. Tune the symbol recognition options.

### Selecting raster symbols



2. Set raster (hybrid) type of selected data
3. Press the **Select Raster Symbol** button on the **Select** toolbar



4. Specify a point inside the raster symbol to select.

**TIPS:** It is recommended that you click a point near the geometric centre of the symbol.

---

*More detailed Information on data selection is provided on page 23*

### Tracing raster symbols

2. Choose tracing mode

---

*Information on tracing modes is provided on page 55*

3. Press the **Trace Symbol** button on the **Raster to Vector** toolbar



4. Specify a point inside the raster symbol to select.

**TIPS:** It is recommended that you click a point near the geometric centre of the symbol.

---

*More detailed Information on tracing is provided on page 53*

### Vectorizing raster symbols

2. If you have several images in your document, select the one(s) to vectorize. You can also select an image fragment or image clip to vectorize.
3. Choose **Raster2Vector** from the **Conversion** menu.

## Batch and Script

### Script Studio

**Script** – is a sequence of operations, which can be executed unattended.

Let us consider an example of creating a Script on the basis of raster

image calibration.

### Prepare data to start Script:

- Prepare document (\*.cws): open the raster image, customize the User Coordinate System (UCS), save the document (Map.cws)
- Prepare calibration template: set calibration pairs – grid and measured points, save the calibration pairs in file (map.tpl)

**INFORMATION:** You can also set calibration pairs and save them in the document file.

### Prepare, save, and start Script (\*.csf):

Define the calibration execution order:

- 1 – open document (\*.cws);
- 2 – start calibration using calibration template (\*.tpl);
- 3 – save document with calibrated image with a different name.

- Choose the command *Script Studio* from the *Tools* menu.

1. Choose *File* from the *Category* list; choose *Open Document* from the list of commands of the *File* category;

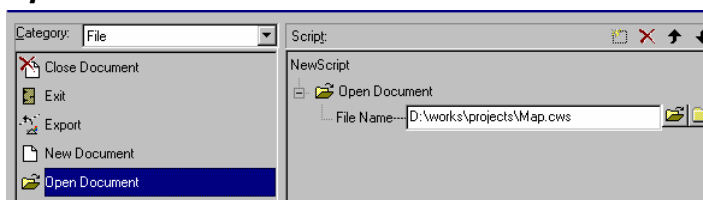

and move the selected command to the *Script* field.

- Click on “+” to open the sub-category, which contains the chosen command options.
- Specify name and folder for the document file - **Map.cws**

2. From the *Category* list, choose *Image*; from the list of commands choose *Calibration*; and move the selected command to the *Script* field.

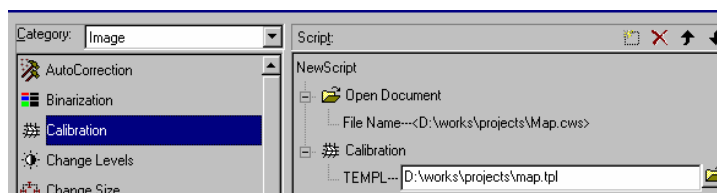

- Open the sub-category of calibration options and specify the pre-defined calibration template file - **map.tpl**

3. From the *Category* list choose *File*; from the list of commands choose *Save as Document*.

- Open the sub-folder of the command options and specify in the *File Name* field - the location and name of the resulting file, and in the *File Type*

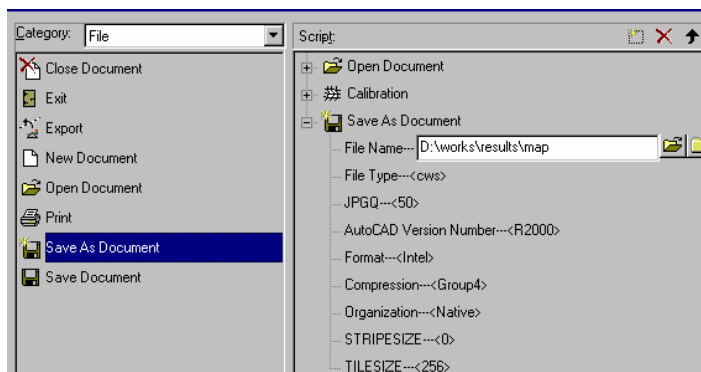

field – the type of the resulting file, for all needed fields.

- To save the Script (\*.csf) file press the *Save As* button of the *Script Studio* dialog.
- To start the Script
  - Press the *Run* button of the *Script Studio* dialog.
  - If the script file has been previously saved, choose *Run Script* from the *Tools* menu, then choose the required script file from the open *Script File* dialog.

When starting a Script, the lower-right corner of the *Edit Script* dialog displays a report on the command execution.

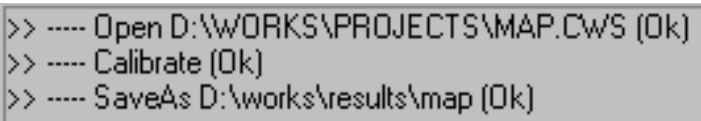

Save the report to file, specify *Set Log File* as the first Script command, selecting name and location of the report file as parameters.

For fast navigation, you can set *All Commands* in the list of categories of the *Edit Script* dialog, and then you can choose a command by pressing its first letter.

## Batch Studio

*Batch* – is a specified sequence of Scripts to process files.

It is convenient to use the Batch option when you need to apply regular operations to several raster images.

Before creating a *Batch*, you need to prepare a set of Scripts, which describe commands for processing. You do not need to describe the commands for opening, inserting and saving files in *Scripts*, prepared for Batch, as these operations are performed with the Batch studio tools.

Look at the following example of creating a Batch:

Prepare data to start Batch:

Prepare script, which perform the commands: Deskew, Crop, Rotate by 90° and save it as Deskew\_Crop\_Rotate.csf

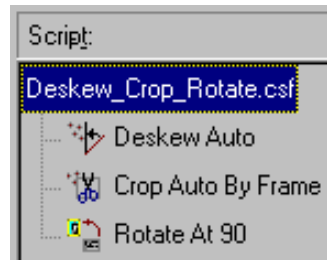

Prepare script, which performs the 4-point correction for images of format ISO A4 and save it as 4p\_correction\_ISO\_A4.csf

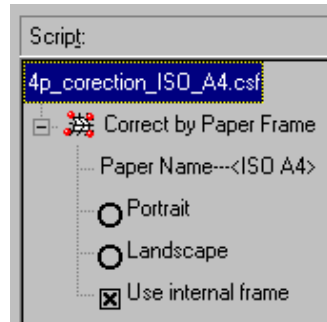

You can create and save scripts in *Script studio*.

*Information on creating Scripts is provided above on page 76.*

**Prepare and start batch**

Choose the *Batch Studio* command from the *Tools* menu

- From the list of folders, located in the left part of the *Batch Studio* dialog, choose the files, or folders with files to process and using drag & drop move them to the *Input files or directories* field.

You can use \* to specify names for files, e.g., if you specify ...\Images\\*.tif, only files with extension tif (contained in the Images folder) will be processed.

- From the list of folders, located in the left part of the *Batch Studio* dialog, select the prepared Scripts files, and drag and drop them to the *Script files list* field.
- If you want to save the processed files in a different folder (with different name or extension), select the *Use output directory* checkbox. Specify a name for the folder. Otherwise, the processed files will overwrite the originals.
- Press the *Run* button.

When starting a Batch, The lower-right corner of the *Run Batch* dialog displays a report on the command execution.

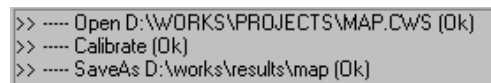

**Customizing Wisel mage**

**Brief description:** In this section you will learn how to customize the interface and various parameters of WiselImage.

## Customizing Program Parameters

Choose *Preferences* from the *Tools* menu.

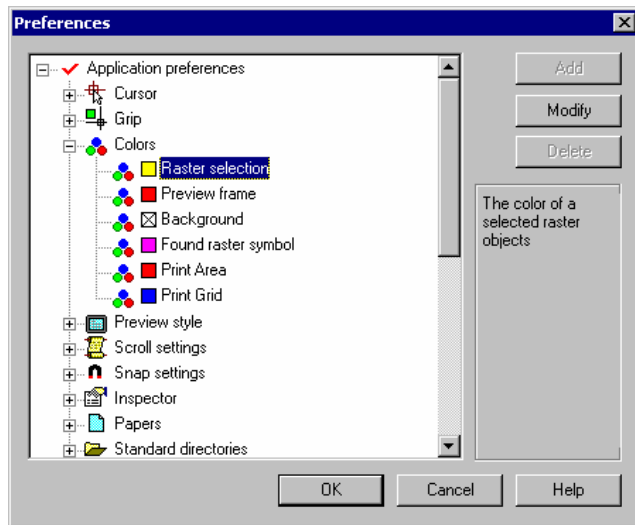

Using the *Preferences* dialog box you can customize the following parameters:

- Cursor's appearance, color and size.
- Size and color of "grips", which appear when selecting objects.
- Colors of interface elements; (e.g., color of selected raster objects, color of the program window background, etc.).
- Preview window style for Binarization.
- Scroll Settings (scroll step, arrows step, Mouse Wheel scale factor)
- Snap settings (aperture size, snap markers' size and color, tooltips display).
- Filter usage mode; setting limit for displaying object properties.
- Modifying the existing standard paper formats and adding new ones.
- Defining the path to OCR template files, symbols to external filters folders.
- List of operations for autocorrect.
- Default properties for new raster images.
- Settings for the *New raster from selection* command (keep or erase the original raster object).
- Properties (width and color) of clipping edge used for vector correction.
- Style and size of markers for vector point display.
- Templates usage.
- Settings for batch script (linear and angle units, default file name and report name).
- Mode of monochrome raster display.
- Turning on/off the use of World-file. (For GIS's users)

This general information includes the description of WiselImage parameters, which can be customized by the user. For more detailed information see the corresponding sections of User's guide and Help.

## Customizing Interface

You can easily customize the WiselImage interface.

To start modifying the interface choose *Customize* from the *Tools* menu.

### Creating a new toolbar

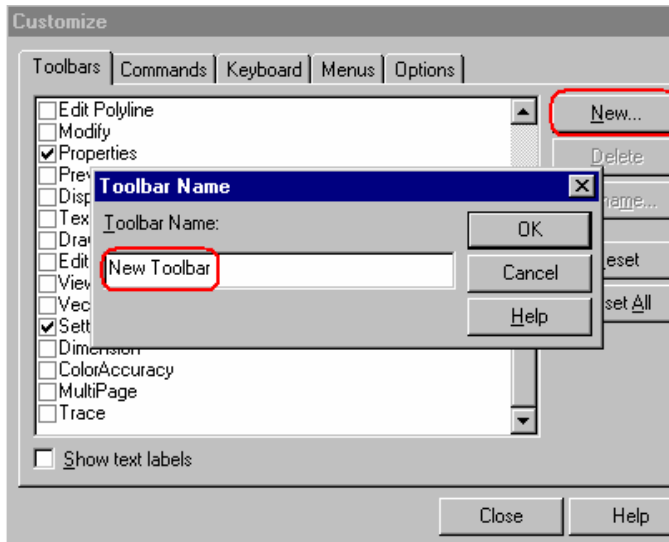

- Press *New* on the *Toolbars* tab
- Specify a name for the new toolbar in the *Toolbar Name* dialog that appears in the list.

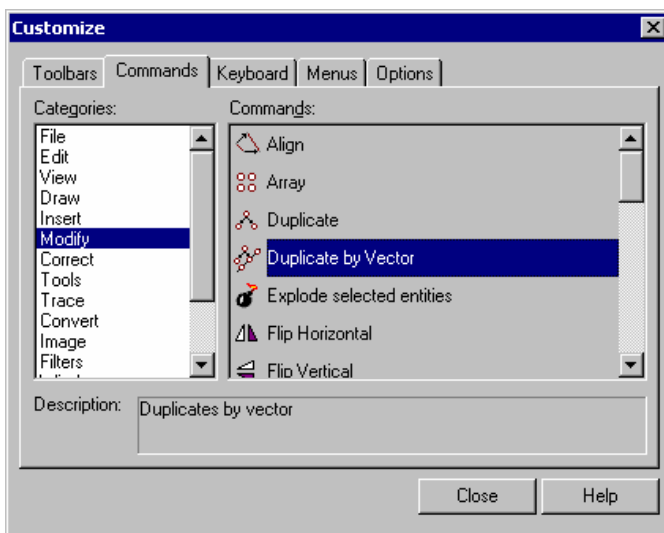

- Go to the *Commands* tab. Select the required group of commands from the *Categories* list, and then choose a command from the *Commands* list and drag it to the newly created toolbar. Repeat this operation for all commands, which you want to place on the new toolbar.

### Modifying a toolbar

Working in this mode, you can rename toolbars, add buttons from the list located in the *Commands* tab, delete and move buttons to other toolbars.

#### How to modify a toolbar

Choose *Customize* from the *Tools* menu.

To rename (delete) a toolbar select it from the list of the *Toolbars* tab and press *Rename (Delete)*.

You can move (delete) buttons using the drag and drop technique.

---

*Information on adding commands from the list of Commands is provided on page 81.*

If you want to reset a modified standard toolbar to its original state, select it and press the *Reset* button in the *Toolbars* tab.

## Turning on/off toolbar display

You can turn on/off the display of toolbars on the screen. For this you can choose **Show Toolbar** from the **View** menu and then select **Check Mark** for desired toolbars.

## Creating a new menu item

Choose **Customize** from the **Tools** menu.

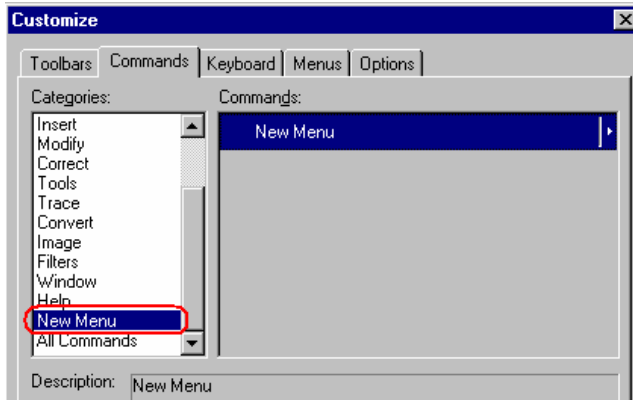

- From the **Categories** list of the **Commands** tab choose **New Menu**.
- Place the cursor on the **New Menu** string of the **Commands** list, click and drag cursor to the menu item string where you want to place the new item.
- You can select commands for a new menu item in the same way as for a new toolbar.

---

*Information on adding commands from the list of Commands is provided on page 81.*

## Modifying a menu

You can rename menu items, add, delete, move and group menu commands.

### How to modify a menu

Choose **Customize** from the **Tools** menu.

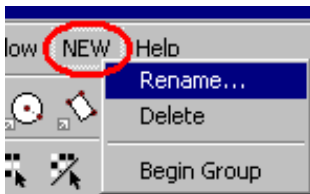

- To rename a menu item: place the cursor over it, right-click and choose **Rename** from the right-button menu.



- If you want to group some menu commands, choose **Begin Group** from the right-button context menu.

- You can move (delete) commands using the drag and drop technique.

---

*Information on adding commands from the list of Commands is provided on page 81.*

If you want to reset all menu items to their original state press the **Reset All** button, located in the **Toolbars** tab. Note that pressing this button resets all interface modifications made by the user.

### Assign acceleration keys

Start customizing the interface by choosing **Customize** from the **Tools** menu. Open the **Keyboard** tab.

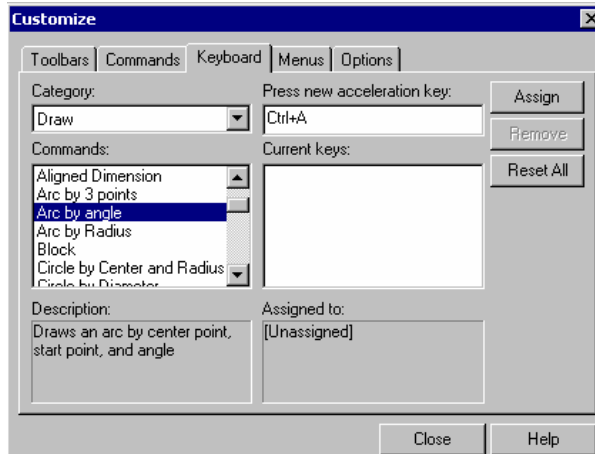

- Select the desired group of commands from **Category**, and then the command from the **Commands** list.
- Enter a desired key combination in **Press new acceleration key** field.
- If this key combination has already been assigned, the name of the command for which this combination is already used appears in the **Assigned to** field.

- Press **Assign**, if this combination is not already used (message: **Unassigned** in the **Assigned to** field).
- To delete the existing acceleration keys, select them from **Current keys** and press **Remove**.

### Modifying context (right-button) menu

You can modify the list of commands contained in context (right-button) menu.

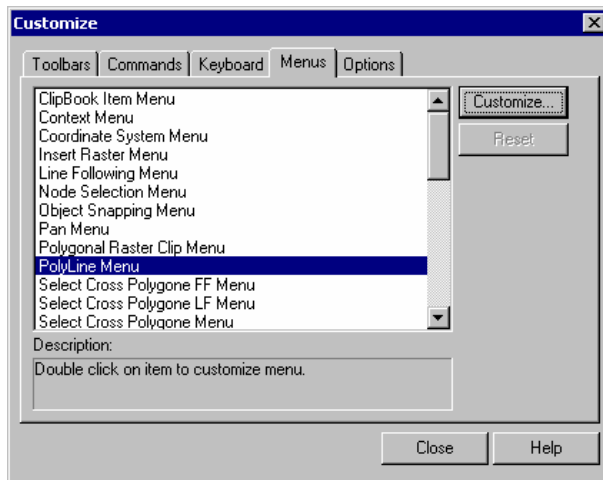

- Choose **Customize** from the **Tools** menu, and then the **Menus** tab.
- Select a command from the list, for which you intend to modify the context (right-button) menu.
- Press the **Customize** button.
- Modify the appeared context menu.

If you want to reset modified context menu to the original, select it from the list and press the **Reset** button.

### Custom Button Size

Button sizes can be tuned freely and styles are completely remastered to achieve a better performance while operating in a wide range of screen resolutions.

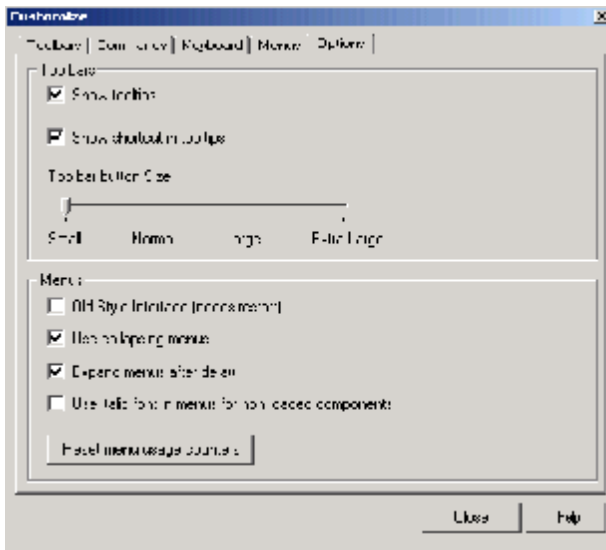

- Choose **Customize** from the **Tools** menu, and then the **Options** tab.
- Modify the appeared settings.

### User Defined Buttons

From now user can create custom toolbars and buttons and assign scripts or command sequences to this new buttons.

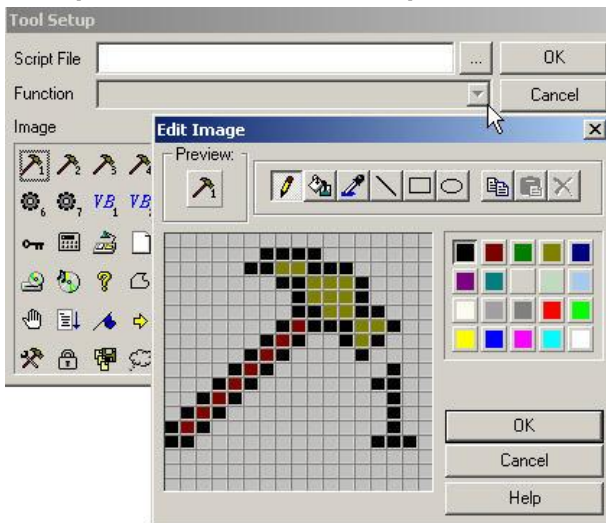

- Choose **Customize** from the **Tools** menu, and then the **Commands** tab.
- On the left bottom corner click on the hammer symbol and drag to the desired toolbar
- By right mouse click on the new button enter **Tool Setup**
- To modify button image select **Edit** in **Tool Setup**

### Multiple Preview Windows

It is a possibility to open several preview windows at a time, during any image enhancement procedure. To launch a new preview window press  button under the active preview window.

### Transparency

Dialog boxes and palettes can be set semi-transparent. To do it press **Ctrl + Right mouse** button on a desired dialog box and set **Window Transparency**.

### Raster Border Control

You can switch off raster border frame, for convenience. To do it, go

